



MODEL 35" and 39" SNACK GLASS FRONT MERCHANDISER ILLUSTRATED PARTS MANUAL

L0072 REV L

AUTOMATED MERCHANDISING SYSTEMS INC
255 WEST BURR BLVD.
KEARNEYSVILLE, WV 25430
304-725-6921 - Fax 304-725-6983

INTERNATIONAL A.M.S. S DE RL DE CV
KM. 9 CARR. AL CASTILLO NO. 8200
MPIO. DE EL SALTO, JAL. MEXICO 45680
5233-3-6-88-07-17 - Fax 5233-3-6-88-13-14

info@amsvendors.com
www.amsvendors.com

www.amsint.com.mx
servicio@amsint.com.mx

THIS PAGE INTENTIONALLY LEFT BLANK

AMS Glass Front Merchandiser
Model 35" and 39" Snack
Illustrated Parts Manual

Table of Contents

SECTION	PAGE
INTRODUCTION	
General Introduction	5
Manual Organization	5
Merchandiser Identification	6
Patent Disclosure	7
Publication Notice	7
CABINET ILLUSTRATIONS	
Cabinet Covers and Screens Illustration	8
Cabinet Left Side and Center Illustration	10
Cabinet Right Side Illustration	14
CHILLER ILLUSTRATIONS	
Chiller Illustration—Angled View	16
Chiller Illustration—Top View	18
Chiller Option—Ventilated Cabinet Illustration	20
DOOR ILLUSTRATIONS	
Door, Coin Bay Illustration	22
Door, Hinges, Glass and Lighting Illustration	24
Door, External Parts Illustration	30
Door, Sensor System and Hopper Illustration	32
Door with Optional Trim and Finish Parts Illustration	36
POS Display Illustration	38
ELECTRICAL HARNESS ILLUSTRATIONS	40
HELIX ILLUSTRATIONS	
Helix Illustrations	56
1.5" Helix Tray Illustration	60
Universal (Snack/Candy/Food) Tray Illustration	62
35" & 39" High Capacity Heavy Product Tray Illustration	66

THIS PAGE INTENTIONALLY LEFT BLANK

GENERAL INTRODUCTION

The purpose of this manual is to give our customers a way of identifying major service parts for repair and replacement. The illustrations and parts list in this manual are for identification only. Some optional parts are also shown.

Illustrations of these major parts are keyed with our part numbers. The illustrations help identify the general design, position and orientation of these parts. The note section may also give important information.

Please refer to the section on merchandiser identification on the following pages. Without the model style and serial number it may be difficult to identify the required part.

Parts should be ordered from your distributor.

It is our intent to assist our customers with up-to-date documentation. However, this manual may not show all parts, variations or changes. Some parts may be shown out of scale. This manual is itself subject to change without notice. If any errors are found, please notify AMS so the correction can be included in later revisions. Engineering data and third party information are generally not included. The graphical data, group assembly data, parts, part assembly, parts breakout information and tabular data conveyed by this manual is proprietary and belongs to AMS, and holders without prior consent of or without knowledge of and by AMS must surrender this data immediately.

All measurements are in inches except where specified as Metric.

MANUAL ORGANIZATION

This manual is divided into general sections. Each section is further divided into the various subsections or subassemblies. These lead off with one or more illustrations showing the parts and each part is identified with a number. Note that some part numbers are for assemblies fabricated as a unit at AMS and are replaceable only as a unit. Also, other part numbers identify optional parts which may or may not have been contracted for and factory installed by AMS.

The part number in the illustration is listed with the description or title for that part. In some instances there may be multiple parts to choose from. The correct service or repair part for the style of merchandiser must be selected. A quantities column in the list indicates quantities required.

There is a note section where additional information may be found.

This manual contains additional and new information for a vendor as currently manufactured. Older revisions of this manual should be kept with older vendors.

MERCHANDISER IDENTIFICATION

When requesting service, replacement parts or technical assistance, please use the **Model Number** and the **Serial Number with Date Code**, found on the Serial Plate (See **Fig. 1** below) affixed to the merchandiser. The plate is usually located inside the window. The information contained on this plate is necessary to determine what parts, kits, or maintenance apply to your vendor.



Fig. 1 Typical Serial Plate

Model Number Breakdown

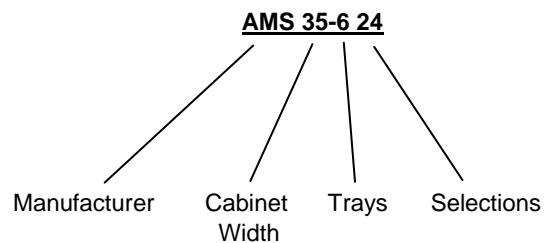

AMS 35 -6-24 means this vendor is an Automated Merchandising Systems merchandiser, **35"** wide, with six (**6**) trays making available twenty four (**24**) positions for different products.

Example of Serial Number Breakdown

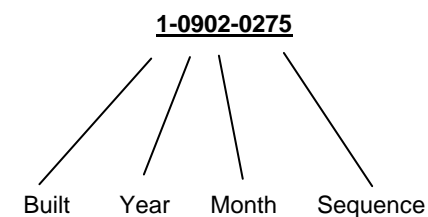

1-0902-0275 is translated as U.S. built (1), manufactured in 2009, month of February, and was the 275th manufactured that year.

Note: Manufactured in Mexico, Built = (2)

The next two digits identify the month. The first month of the year is **01** and the last month is **12**.

PATENT DISCLOSURE

This merchandiser and/or certain of its components are covered by one or more of the following U.S. and international patents;

U.S. PATENTS: 6,145,699; 6,384,402; 6,520,373; 6,708,079; 6,794,634; 7,191,915; 7,343,220; 7,742,837; 7,446,302; 8,003,931

CANADIAN PATENT: 2,329,314

MEXICO PATENT: 230,714

PUBLICATION NOTICE

L0072, Revision L, ECN 3805, 8/15/16

It is our intent to assist our customers with up-to-date documentation: however, this manual may not contain all updates and is subject to revision without notice. Please contact our Service Department with your requests or comments.

CABINET COVERS AND SCREENS ILLUSTRATION

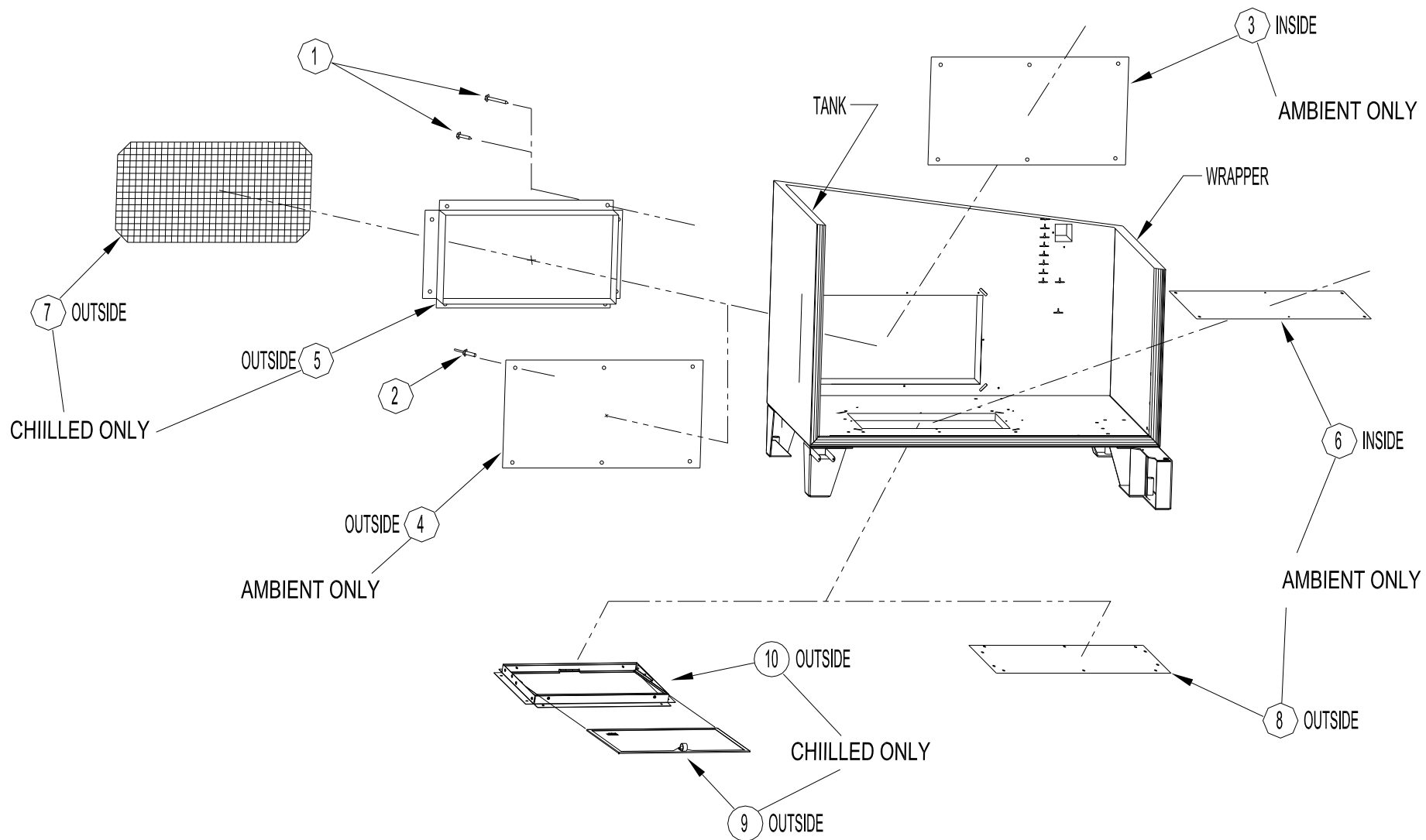

CABINET COVERS AND SCREENS PARTS LIST

ITEM	PART NO.	PART DESCRIPTION	QTY.	NOTES
1	3000	Screw, Sheet Metal, TEK 8-18 (1/2" Long)		For One Trim
	3000-06	Screw, Sheet Metal, TEK 8-18 (3/4" Long)		For Rear Trim When Option P/N 21308 Is Installed
2	3009-02	Rivet, Pop, Steel, 1/8 (1/4" Long)	8	Quantities For One Cover
3	20187	Wrapper, Rear Chiller Hole Cover	1	Use For Ambient (No Chiller) Option
4	20187	Wrapper, Rear Chiller Hole Cover	1	Use For Ambient (No Chiller) Option
5	20275	Trim, Rear Chiller Hole	1	
6	20375	Tank - Rear Chiller Hole Cover (35")	1	Use For Ambient (No Chiller) Option
	20187	Wrapper, Rear Chiller Hole Cover (39")		
7	21308	Screen, Expanded Metal, Rear Chiller Hole	1	Add To Other Rear Screens
	20279	Screen, Rear Chiller Hole (39"), 4 Mesh.	1	1/4" x 1/4"
8	21481	Wrapper- Bottom Chiller Hole Cover (35")	1	Use For Ambient (No Chiller) Option
	20187	Wrapper- Bottom Chiller Hole Cover (39")		
9	21469	Screen, Bottom, Insect (35"), Ver. 2 Aluminum 18 x16 Mesh	1	
	23262	Screen, Rear Chiller Hole, (39") 8 Mesh (1/4" x 1/4")		
10	21464	Trim, Bottom Chiller Hole (35") Ver. 2	1	
	23263	Trim, Rear Chiller Hole (39")		

NOTE: The rear opening and the bottom opening are not the same size on 35" Cabinets (ECN 1770). All screen materials are fitted to trim parts, and trim parts are attached to the outside of the cabinet with screws. The combination of screens may differ. Covers to seal the cabinet are always attached flush inside and outside the cabinet (without using trim) with rivets.

CABINET LEFT SIDE AND CENTER ILLUSTRATION

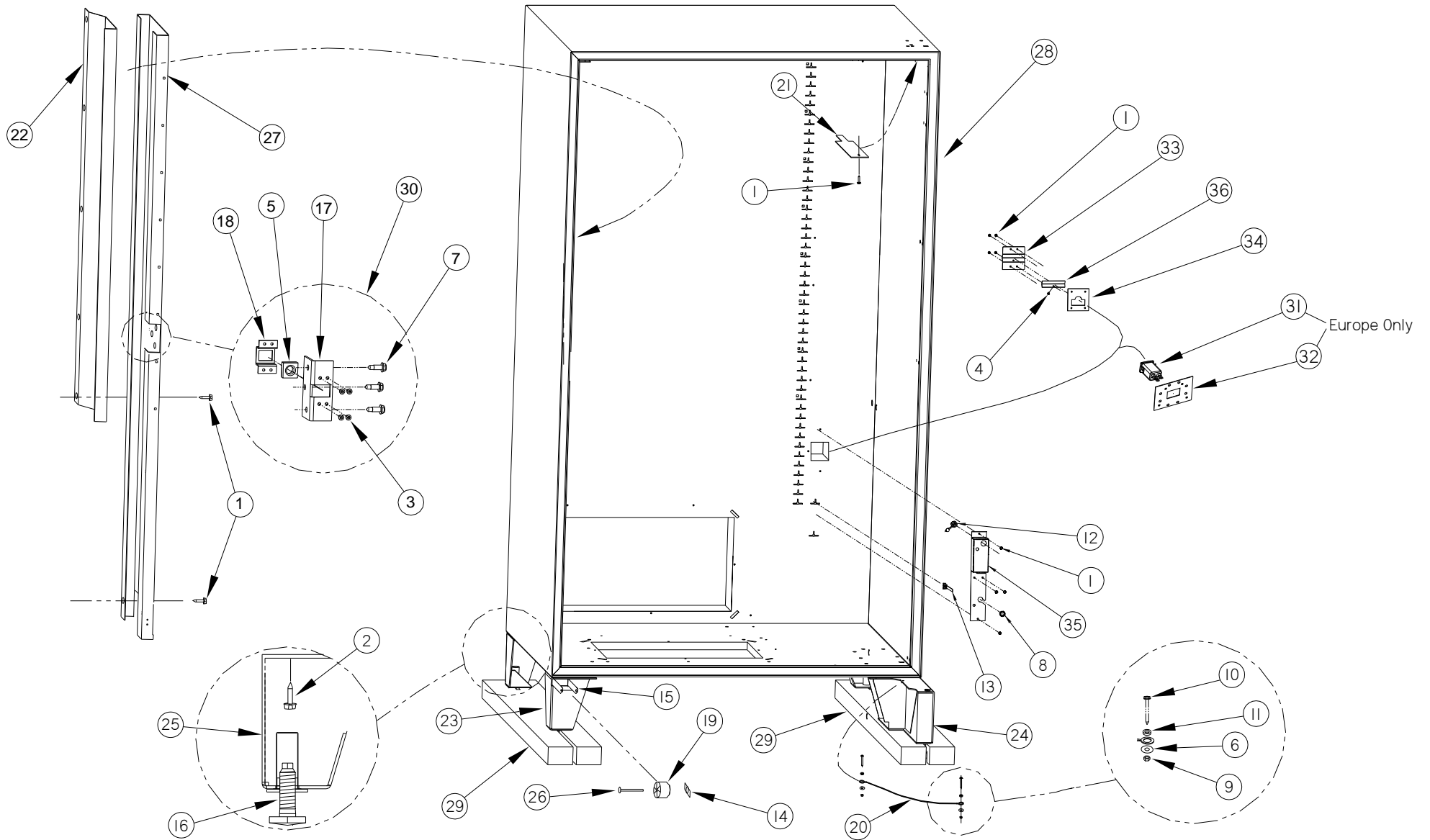

CABINET LEFT SIDE AND CENTER PARTS LIST

ITEM	PART NO.	PART NAME	QTY.	NOTES
1	3000	Sheet Metal Screw TEK #8-18	54	
2	3007-06	Screw, 5/16-18, Type F	16	4 Per Leg
3	3009-04	Rivet, Steel, 1/8", 1/4" Grip, Blk	4	
4	3009-02	Steel Rivet, 3/8" Grip Length 1/4"	1	
5	3010	Nut, Square, Machine	1	
6	3017-10	Washer, #10 SAE Flat	2	For Door Stop Cable (2 Places)
7	3018-06	Screw, Sheet Metal, TEK-8-18	3	For Lock Assembly
8	3029-02	Bushing, Open/Closed	1	
9	3060-10	Nut, 10-32, w/Nylon Insert	2	For Door Stop Cable (2 Places)
10	3061-06	Screw, 10-32 x 3/4 Phillips Pan Head	2	For Door Stop Cable (2 Places)
11	3067	Spacer, .192 ID x .125 Length x 3/8 Dia.	2	For Door Stop Cable (2 Places)
12	3080	Strain Relief, Button Lock	1	
13	3081	Wire Tie, 0.250 Panel Mount	1	
14	3113	Push Nut, 3/16" Stud	1	
15	20019	Leg, Roller Bracket	1	
16	20121	Leveling Leg	5	Cabinet To Be Leveled Using All Legs
17	20135	Lock, Flange	1	
18	20136	Lock, Cage	1	
19	20177	Roller, Molded (Nylon)	1	
20	20227	Cable Assembly, Door Stop, Modified	1	
21	20291	Cover Plate, Hinge Hole, Ver. 2	1	For Top Hinge
22	20481	Extension, Left Vertical Rail Mount	1	
23	21122	Assembly, Leg, Left Front with Thread Covers	1	
24	21123	Assembly, Leg, Front Hinge With Thread Covers	1	
25	21124	Assembly Leg, Rear with Thread Covers	2	
26	21250	Shaft, Headed Roller (Zinc Plated)	1	
27	21839	Rail Mount, Left Vertical Ver. 2	1	

ITEM	PART NO.	PART NAME	QTY.	NOTES
28	21989	Assembly, Cabinet, (35")	1	Contact AMS for your application
	22071	Assembly, Cabinet, (39")	1	
29	23231	Shipping Board	2	40" Long, Not Treated, (DOM)
	23231-02	Shipping Board		38-3/8" Long, Not Treated, (DOM)
	23231-01	Shipping Board		40" Long, Treated (ISPM 15), (EXPORT)
	23231-03	Shipping Board		38-3/8" Long, Treated (ISPM 15), (EXPORT)
30	23305	Assembly, Low Temp/Snack Cabinet Lock	1	
31	3827	Power Entry Module, 230V	1	Europe Only
32	25464	Plate, Power Entry Module, CE	1	Europe Only
33	25741	Sheet Metal Screw TEK #8-18	54	
34	25742	Liner, Power Cord Exit	1	
35	25790	Cover, Wire Bushing	1	
36	25791	Sheet Metal Screw, 1/4"	3	For Lock Assembly

THIS PAGE INTENTIONALLY LEFT BLANK

CABINET RIGHT SIDE ILLUSTRATION

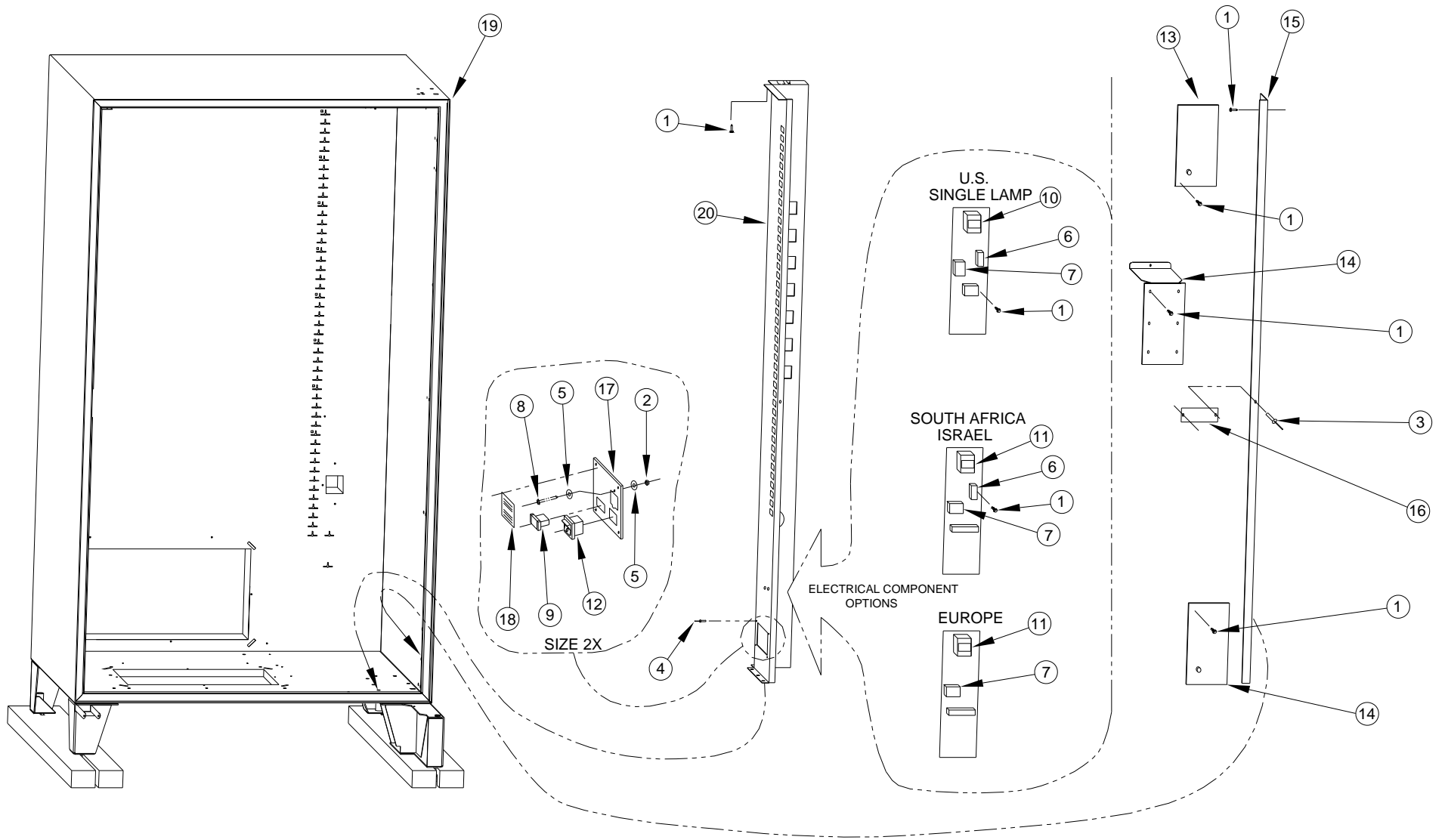

CABINET RIGHT SIDE PARTS LIST

ITEM	PART NO.	PART NAME	QTY.	NOTES
1	3000	Sheet Metal Screw TEK #8-18	54	
2	3006-08	Nut, 8-32, Hex, Machine Screw	1	For Attaching Power Harness
3	3009-02	Rivet, Pop, Steel, 1/8 x 1/4 Grip Length	2	
4	3009-04	Rivet, Pop, Steel, 1/8 x 3/8" Grip Length	4	For Attaching 21479
5	3017-10	Washer, #10 SAE Flat	2	For Power Harness
6	3030	Filter, R.F.I	1	For Filtering Electrical Noise
7	3274	Relay, Refrigeration, Single Pole	1	For 24V Control of Optional Chiller
8	3084-10	Screw, Sems, 8-32	1	For Power Harness
9	3133-30	Assembly, Fuse Holder With Fuses	1	Use P/N 3097 3AG Fast Blow Fuse Only
10	3257	Transformer, Class II, 120V / 24V	1	For Power
11	3258	Transformer, CE, 230V / 24V	1	For Power
12	3284	Switch, Rocker, On/Off	1	For 24VAC Circuit Control
13	20207	Cover Plate, Column, Fixed	2	
14	20211	Cover Plate, Transformer	1	
15	20213	Flange, Right Vertical	1	
16	21053	Stiffener, Right Vertical Rail Mount	1	
17	21479	Plate, Fuse Holder, Socket And Power Switch Mount	1	Attached Inside of Rail Mount
18	21509	Decal, 24V Fuse, Ver. 2	1	
19	23305	Assembly, Cabinet, (35")	1	Contact AMS for your application
	22071	Assembly, Cabinet, (39")		
20	23724	Rail Mount, Right Vertical, Snack, (35")	1	
	21476	Rail Mount, Right Vertical, Snack, (39")		

CHILLER ILLUSTRATION—ANGLED VIEW

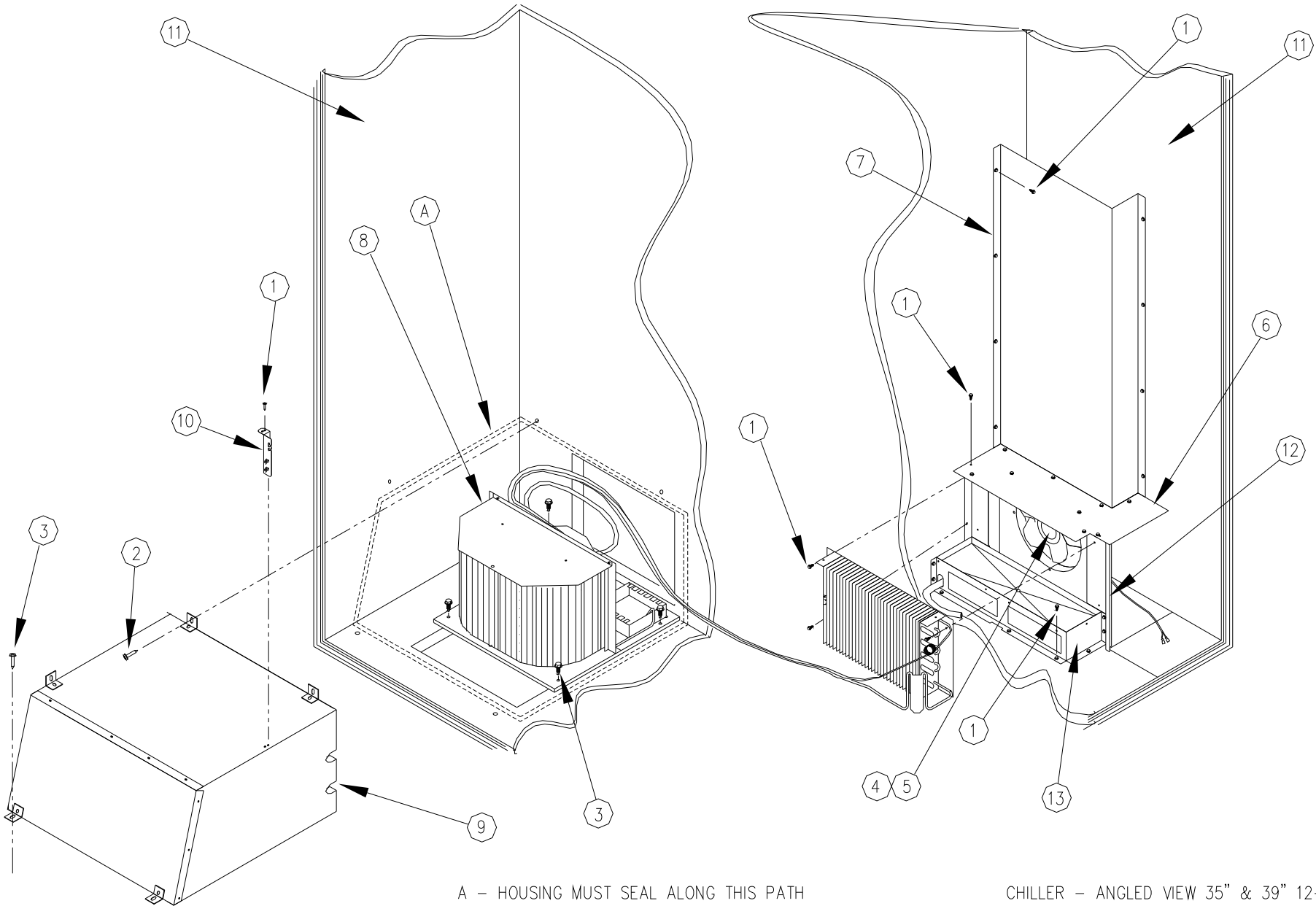

A - HOUSING MUST SEAL ALONG THIS PATH

CHILLER - ANGLED VIEW 35" & 39" 12-12-13

CHILLER PARTS LIST - ANGLED VIEW				
ITEM	PART NO	PART DESCRIPTION	QTY	NOTES
1	3000	Sheet Metal Screw TEK #8-18	46	
2	3018-06	Screws, ¼ x ¾, Self Tapping, Hex Head	2	For Attaching To Tank Walls
3	3018-08	Screws, ¼ x 1, Self Tapping, Hex Head	6	For Attaching To Tank Floor
4	3106	Evaporator Fan/Motor Assembly, 220V, 50Hz, 1 Phase	1	Note Voltage!
5	3107	Evaporator Fan/Motor Assembly, 110V, 60Hz, 1 Phase		
6	21987	Evaporator Cover Plate (35")	1	
	20316	Evaporator Cover Plate (39")		
7	20317	Evaporator Plenum	1	
8	25633	Assembly, 1/4, Chiller, 120V	1	See Note
	20531	Assembly, 1/4, Chiller, 220V		
9	23304	Assembly, Chiller Housing, English (35")	1	Housing must seal against Cabinet As Shown
	23304-01	Assembly, Chiller Housing, Spanish (35")		
	22105	Assembly, Chiller Housing, English (39")		Housing must seal against Cabinet As Shown. Supplied with access Door.
	22105-01	Assembly, Chiller Housing, Spanish (39")		
10	21424	Bracket, Temperature Sensor, Sensit II	1	
11	23305	Assembly, Cabinet, (35")	1	Contact AMS For Your Application
	22071	Assembly, Cabinet, (39")		
12	21991	Evaporator Mounting Panel, Stamped Drain Pan	1	For Stamped Pan Assemblies
13	21992	Assembly, Stamped Evaporator Drain Pan	1	Use with 21991, Evaporator Mounting Panel

NOTE: Chiller assemblies are charged with refrigerant and are replaceable only as an assembly. The refrigeration system is pressurized and sealed at the factory. Puncturing or cutting any component in the system will cause refrigerant gas and liquid to be propelled out of the system, creating an immediate physical hazard. Use caution to avoid accidentally opening the refrigerant system. It should also be noted that releasing refrigerant to the atmosphere is a federal crime and is punishable by law. Any service work requiring the system to be opened must be performed by a licensed technician using certified recovery equipment. Unauthorized service to the sealed refrigerant system may void the warranty.

Ambient snack merchandisers have no chillers or chiller parts. Ventilated merchandisers have a forced air system without any chiller.

CHILLER ILLUSTRATION—TOP VIEW

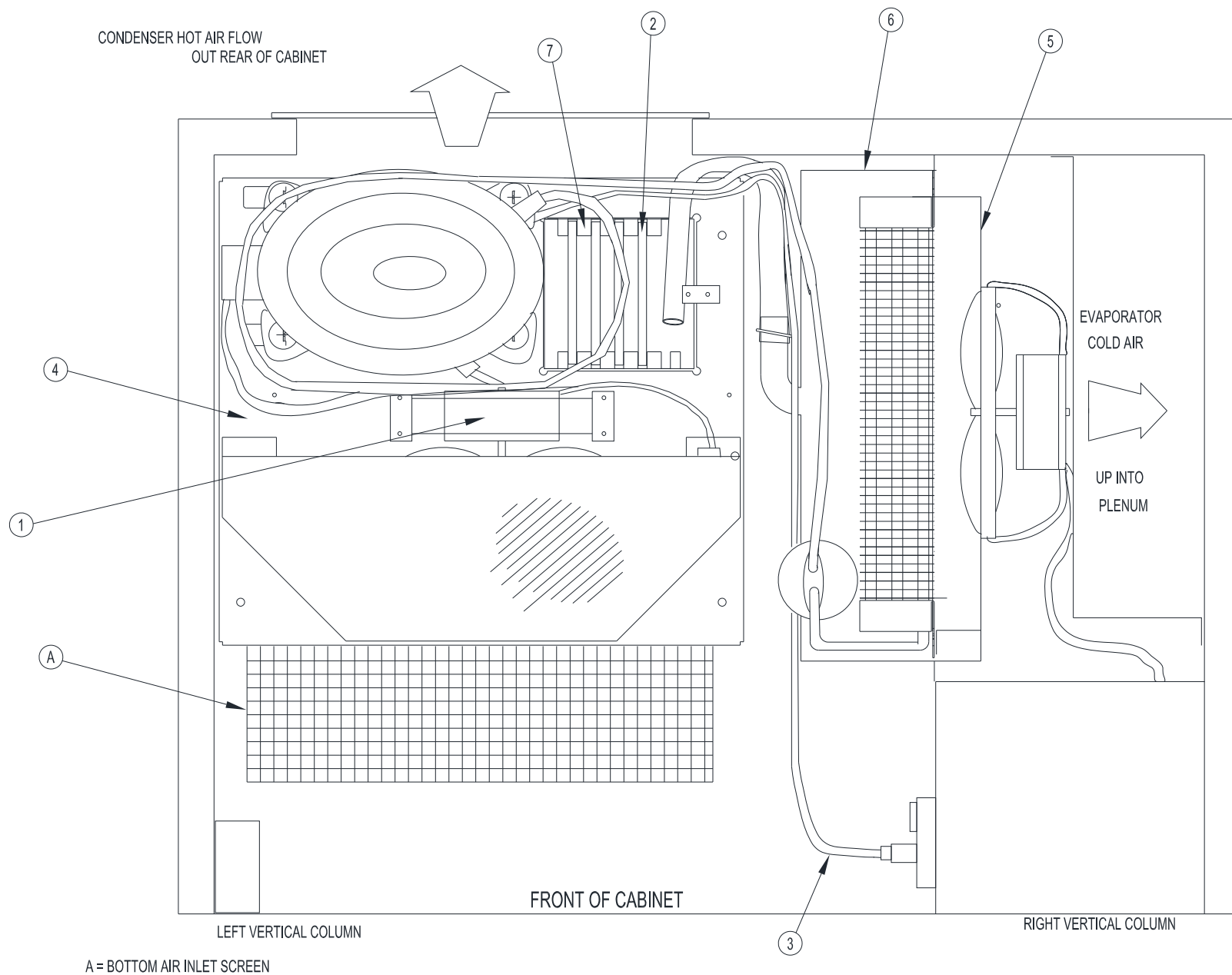

CHILLER PARTS LIST - TOP VIEW

ITEM	PART NO.	PART DESCRIPTION	QTY.	NOTES (See Note A Below)
1	3065	Fan, Condenser Assembly, 220V, 50Hz, 1 Phase	1	Note Voltage!
	3108	Fan, Condenser Assembly, 110V, 60Hz, 1 Phase		Note Voltage!
2	3093	Sponge (Condenser Drain Pan)	4	
3	20144	Refrigeration Harness	1	Use with Both 110V or 220V Systems
4	20531	Assembly, 1/4 H.P. Chiller, 240V, Ver. 2, AMS (WV)	1	See Note A
	25633	Assembly, 1/4 H.P. Chiller, 120V, Ver. 2, AMS (WV)		
5	21991	Evaporator Mounting Panel, Stamped Drain Pan	1	Used with Stamped Pan Assemblies
6	21992	Assembly, Stamped Evaporator Drain Pan	1	Use with 21991, Evaporator Mounting Panel
7	27460	Condenser Drain Pan Assembly, Formed	1	Stamped Fabrication with 4 Sponges

NOTE A: Chiller assemblies are charged with refrigerant and are replaceable only as an assembly. The refrigeration system is pressurized and sealed at the factory. Puncturing or cutting any component in the system will cause refrigerant gas and liquid to be propelled out of the system, creating an immediate physical hazard. Use caution to avoid accidentally opening the refrigerant system. It should also be noted that releasing refrigerant to the atmosphere is a federal crime and is punishable by law. Any service work requiring the system to be opened must be performed by a licensed technician using certified recovery equipment. Unauthorized service to the sealed refrigerant system may void the warranty.

Ambient snack merchandisers have no chillers or chiller parts. Ventilated merchandisers have a forced air system without any chiller.

CHILLER OPTION—VENTILATED CABINET ILLUSTRATION

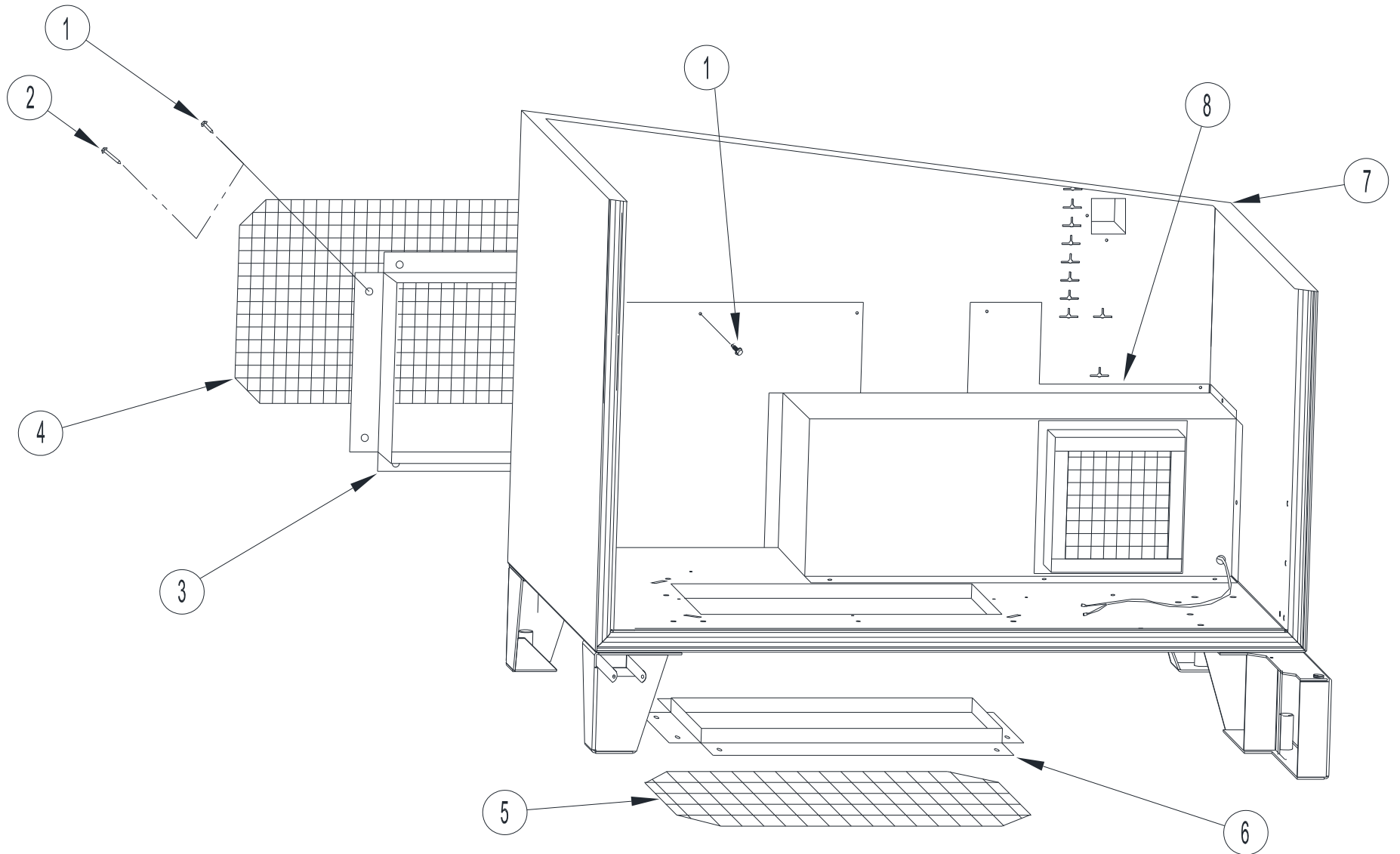

CHILLER OPTION—VENTILATED CABINET ILLUSTRATION

ITEM	PART NO.	PART DESCRIPTION	QTY.	NOTES
1	3000	Screw, Sheet Metal, TEK 8-18	16	Qty. For Two Trim Parts
			12	Qty. For Ventilator Assembly
2	3000-06	Screw, Sheet Metal, TEK 8-18	8	Replace Item 1 For Rear Trim only When Option P/N 21308 is Installed
3	20275	Trim, Chiller Hole	1	
4	21040	Screen, Rear Chiller Hole, 8 Mesh (1/4" X 1/4")	1	
	21308	Screen, Expanded Metal, Rear Chiller Hole	1	Add to other rear screens
5	21463	Screen, Bottom Chiller Hole, (35") 8 Mesh, Ver. 2	1	
	20279	Screen, Rear Chiller Hole		
6	21464	Trim, Bottom Chiller Hole (35") Ver. 2	1	
	20275	Trim, Chiller Hole (39")		
7	21989	Assembly, Cabinet, (35")	1	Tank is Inside, Wrapper is Outside
	22071	Assembly, Cabinet, (39")		
8	23303	Assembly, Ventilator, Ver. 3, (35") 110V	1	
	22080	Assembly, Ventilator, Ver. 4, (39") 110V		

NOTE: The rear opening and the bottom opening are not the same size on 35" Cabinets (ECN 1770). All screen materials are fitted to trim parts, and trim parts are attached to the outside of the cabinet with screws. The combination of screens may differ. Covers are not used. Cabinet is shown without any other parts.

Ambient snack merchandisers have no chillers or chiller parts. Chiller units provide refrigeration in the cabinet.

DOOR, COIN BAY ILLUSTRATION

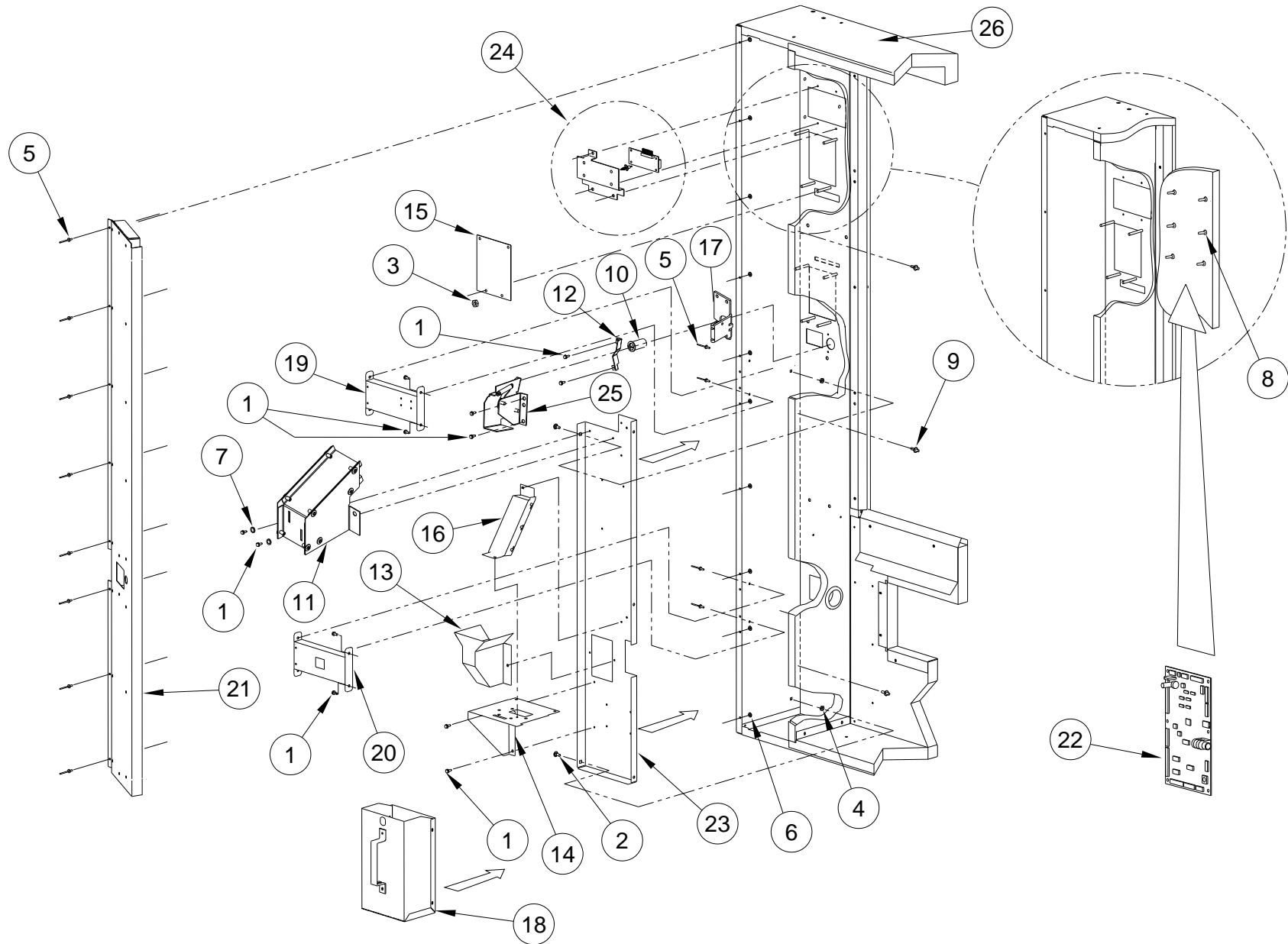

DOOR, COIN BAY PARTS LIST

ITEM	PART NO.	PART NAME	QTY.	NOTES
1	3000	Screw, Sheet Metal TEK 8-18	18	
2	3005-04	Carriage Bolt, #10-24, 1/2"	5	
3	3006-08	Nut, Hex, Machine Screw, #8-32	8	4 per DBV Opening
4	3006-10	Nut, Hex, Machine Screw, #10-24	5	
5	3009-04	Rivet, Steel, 1/8", Black, Grip Length 1/4"	12	
6	3017-06	Washer, Flat Steel, SAE Std., #6 Screw 5/32	10	
7	3017-10	Washer, Flat Steel, SAE Std., #10 Screw 7/32 x 1/2	2	
8	3037-01	PC Board Support (3/16")	6	For Control Board
9	3038	Rivet, Nylon, Trim	2	Hold Door Closed
10	20081-01	Scavenger Button, Blk	1	
11	24631	Assy., Coin Chute, Upper	1	
12	24641	Scavenger Guide, Epoch	1	
13	23373	Assembly, Plastic Coin Cup	1	
	23373-01	Assembly, Plastic Coin Cup, Gray	1	
14	24961	Coin Box Bulkhead	1	
15	20181	DBV Cover Plate	2	Flat Steel Plate, 1 per DBV Opening
16	24962	Assembly, Coin Chute, Lower	1	
17	24642	Bracket, Pushbutton Alignment, Epoch	1	
18	24613	Assembly, Coin Box Epoch & ADA Short	1	
19	20706	Door Stiffener, Upper, Without Fuse And Switch	1	Not Shown
	20709	Door Stiffener, Upper, Locking, w/o Fuse And Switch		
20	20707	Door Stiffener, Bottom With Switch	1	
21	20752	Assembly, Coin Door, Upper (51")	1	
22	26910	Control Board, Isolated LED Power	1	
23	24608	Mounting Panel, Changer, Multi-Use	1	
24	24739-03	Assembly, Display, Ver. 3, Escutcheon (OLED)	1	Contains display board
25	24625	Assembly, Scavenger System, VER. 3, ADA Escutcheon, Epoch	1	
26	25222	Assy., Foamed Door, Snack, Epoch (35")	1	Contact AMS for your application.
	25106	Assy., Foamed Door, Snack, Epoch-ADA (35")		
	25220	Assy., Foamed Door, Snack, Epoch (39")		
	25083	Assy., Foamed Door, Snack, Epoch-ADA (39")		

DOOR, HINGES, GLASS AND LIGHTING ILLUSTRATION

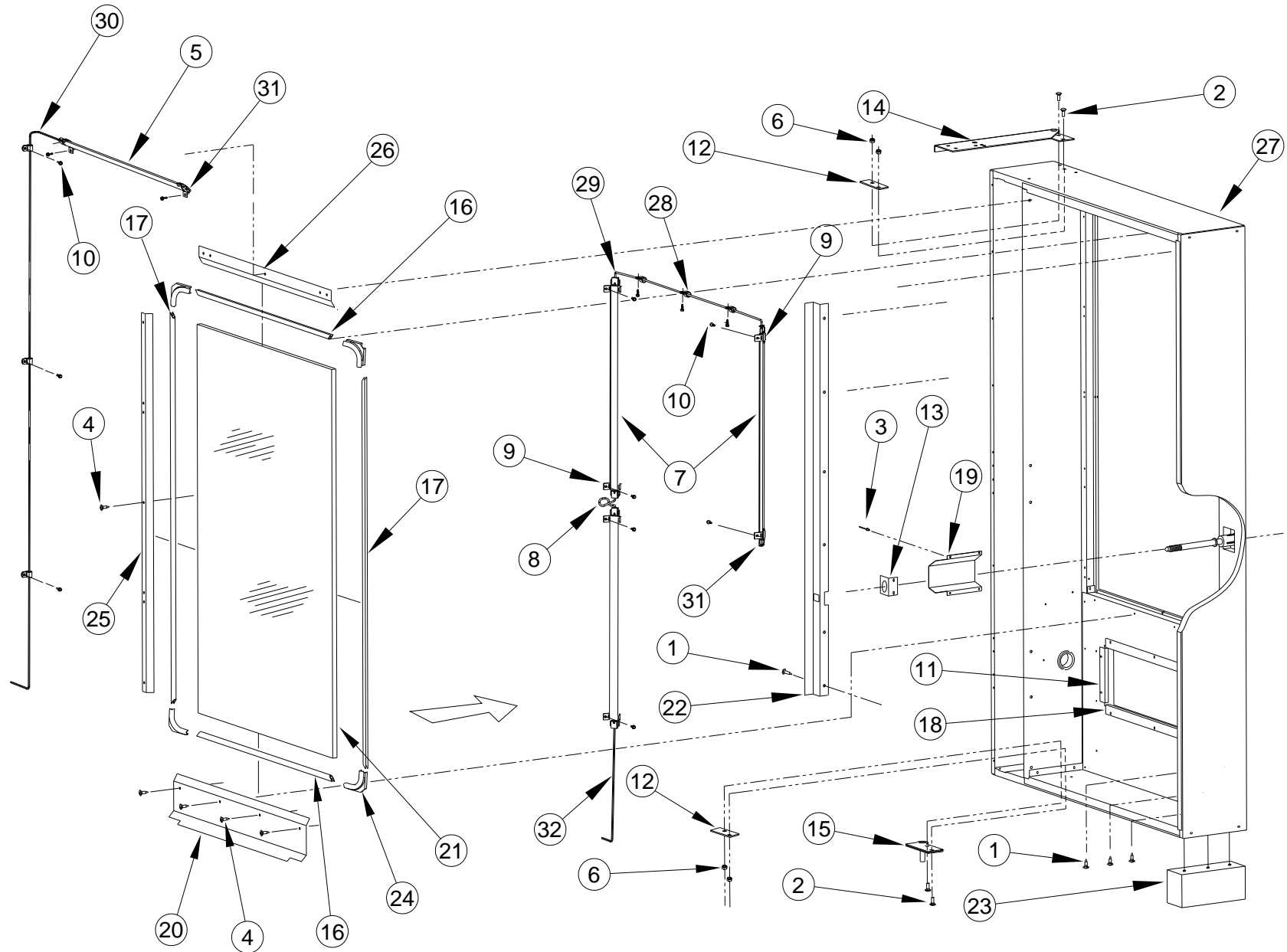

DOOR HINGES, GLASS AND LIGHTING LAMPS PARTS LIST

ITEM	PART NO.	PART DESCRIPTION	QTY.	NOTES
1	3000	Sheet Metal Screw TEK #8-18	14	
2	3004-06	Carriage Bolt, 1/4-20, 3/4"	4	
3	3009-02	Rivet, Pop, Steel, 1/8 Diameter	4	
4	3000	Sheet Metal Screw TEK #8-18	20	For Glass Retainers
5	26989	LED Assembly, ETI 19"	1	For Single LED Option
6	3153-11	Nut, Hex With Lock Washer	4	
7	26989	LED Assembly, ETI 19"	3	For Dual LED Option
8	26990-03	Harness, LED Connector Cable, 3"	1	For Dual LED Option
9	26976	LED Clip, Ver. 2	6	For Dual LED Option
10	3342-04	Screw, Sheet Metal, TEK 8-18, Clear Zinc, 1/2" L	9	For Dual LED Option
11	22381	Retainer, Vertical Eyelet	2	
12	20206	Hinge, Washer Plate	2	
13	20244	Lock Bolt Mounting Bracket	1	
14	21703	Assembly, Top Hinge, 3/16"	1	
15	21704	Assembly, Bottom Hinge Bottom, 3/16"	1	
16	24761-13	Extrusion, Glass Installation, Ver. 2, 16.91 (35")	2	Horizontal
	24761-11	Extrusion, Glass Installation, Ver. 2, 22.38 (39")		
17	24761-14	Extrusion, Glass Installation, Ver. 2, 36.59 (35")	2	Vertical
	24761-12	Extrusion, Glass Installation, Ver. 2, 37.68 (39")		
	24761-16	Extrusion, Glass Installation, Ver. 2, 31.68 (Epoch-ADA 35" & 39")		
18	20401	Retainer, Horizontal Eyelet	2	
19	20447	Lock Bolt Cover, Black	1	
	20447-01	Lock Bolt Cover, White		

ITEM	PART NO.	PART DESCRIPTION	QTY.	NOTES
20	21215	Retainer, Glass Window, Bottom, 1/8" (35")	1	Ambient/Vent. (Single Pane Option)
	21213	Retainer, Glass Window, Bottom, 1/8" (39")		
	21228	Retainer, Dual Glass Window, Bottom, 5/8" (35")		Chilled (Dual Pane Option)
	21225	Retainer, Dual Glass Window, Bottom, 5/8" (39")		
	25126-01	Retainer, Glass Window, Bottom, 1/8", Epoch-ADA (35")		Ambient/Vent. (Single Pane Option)
	21213-01	Retainer, White Glass Window, Bottom, 1/8", Epoch-ADA (39")		
	25216-01	Retainer, White Dual Glass Window, Bottom, 5/8", Epoch-ADA (35")		Chilled (Dual Pane Option)
	21225-01	Retainer, White Dual Glass Window, Bottom, 5/8", Epoch-ADA (39")		
21	21217	Window, Glass, Single Pane, 1/8" (35")	1	Ambient/Vent. (Dual Pane Option)
	21216	Window, Glass, Single Pane, 1/8" (39")		
	21219	Window, Glass, Dual Pane, 5/8" (35")		Chilled (Dual Pane Option)
	21218	Window, Glass, Dual Pane, 5/8" (39")		
	25093	Window, Glass, Single Pane, 1/8", Epoch-ADA (35")		Ambient/Vent. (Single Pane Option)
	25090	Window, Glass, Single Pane, 1/8", Epoch-ADA (39")		
	25094	Window, Glass, Dual Pane, 5/8", Epoch-ADA (35")		Chilled (Dual Pane Option)
	25091	Window, Glass, Dual Pane, 5/8", Epoch-ADA (39")		
22	21051	Tray Restraint, Reduced Depth, Snack, Black	1	
	21051-01	Tray Restraint, Reduced Depth, Snack, White		
23	21165	Assembly, False Leg	1	Install When Vendor is Installed on Site
24	24099	Corner, Window Trim, Plastic	4	

ITEM	PART NO.	PART DESCRIPTION	QTY.	NOTES
25	21211	Retainer, 42" Glass Window, Vertical, 1/8" (35")	1	Ambient/Vent. (Dual Pane Option)
	21210	Retainer, 42" Glass Window, Vertical, 1/8" (39")		
	21227	Retainer, 42" Dual Glass Window, Vertical, 5/8" (35")		Chilled (Dual Pane Option)
	21224	Retainer, 42" Dual Glass Window, Vertical, 5/8" (39")		
	25201-01	Retainer, 36" Glass Window, Vertical, 1/8", Epoch-ADA (35")		Ambient/Vent. (Dual Pane Option)
	21224	Retainer, 36" Glass Window, Vertical, 1/8", Epoch-ADA (39")		
	25217-01	Retainer, White, 36" Dual Glass Window, Vertical, 5/8", Epoch-ADA (35" & 39")		Chilled (Dual Pane Option)
26	21214	Retainer, Glass Window, Top, 1/8" (35")	1	Ambient/Vent. (Dual Pane Option)
	21212	Retainer, Glass Window, Top, 1/8" (39")		
	21226	Retainer, Dual Glass Window, Top, 5/8" (35")		Chilled (Dual Pane Option)
	21223	Retainer, Dual Glass Window, Top, 5/8" (39")		
	21214-01	Retainer, Glass Window, Top, 1/8", Epoch-ADA (35")		Ambient/Vent. (Dual Pane Option)
	21212-01	Retainer, Glass Window, Top, 1/8", Epoch-ADA (39")		
	21226-01	Retainer, Dual Glass Window, Top, 5/8", Epoch-ADA (35")		Chilled (Dual Pane Option)
	21223-01	Retainer, Dual Glass Window, Top, 5/8", Epoch-ADA (39")		
27	25222	Assy., Foamed Door, Snack, Epoch (35")	1	Contact AMS for your application.
	25106	Assy., Foamed Door, Snack, Epoch-ADA (35")		
	25220	Assy., Foamed Door, Snack, Epoch (39")		
	25083	Assy., Foamed Door, Snack, Epoch-ADA (39")		
28	3024-06	Cable Clamp, 3/8" Dia. Black Nylon	3	For Single or Dual

ITEM	PART NO.	PART DESCRIPTION	QTY.	NOTES
29	26990-32	Harness, LED Connector Cable, 32"	1	
30	26991-112	Harness, LED Connector Cable, 112"	1	
31	30044	Receptacle, Connector/PCB Housing, Nylon, Ellenby Lighting	1	
32	26991-70	Harness, LED Connector Cable, 70"	1	

THIS PAGE INTENTIONALLY LEFT BLANK

DOOR, EXTERNAL PARTS ILLUSTRATION

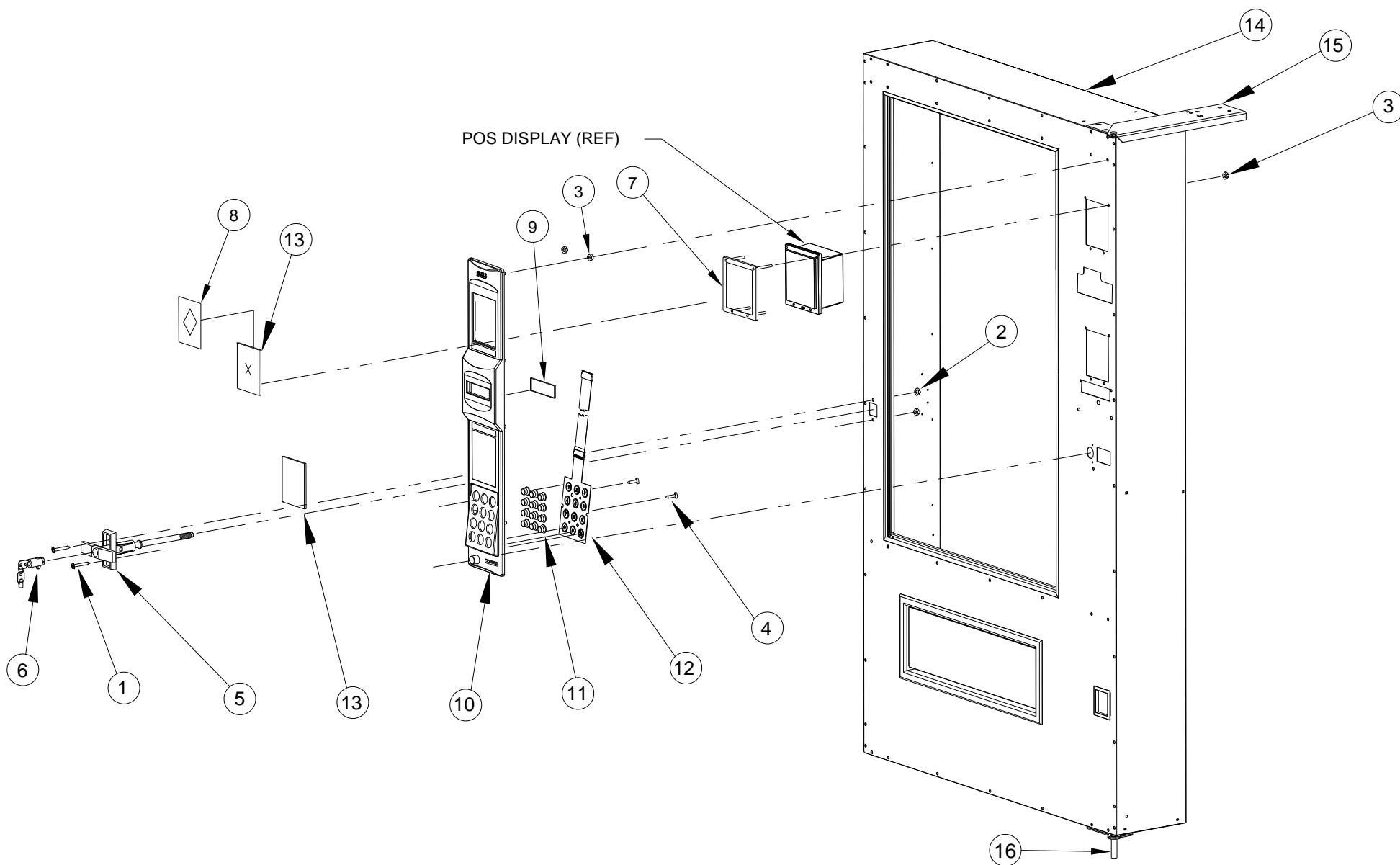

DOOR, EXTERNAL PARTS LIST

ITEM	PART NO.	PART NAME	QTY.	NOTES
1	3005-04	Carriage Bolt, #10-24, 1/2" Long	2	For Securing T-handle
2	3006-10	Nut, Hex, Machine Screw, #10-24	2	For Securing T-handle
3	3011	Self Threading Nut, 1/4" Stud	8	For Securing Escutcheon
4	3289-02	Screw, Type B, #8, Pan Head, Phillips #2	2	For Securing Keypad
5	20130	T-Lock Assembly	1	
6	20131	Lockset And Keys	1	Contact AMS for your application
7	20344	Assembly, DBV Mounting Bezel	2	
8	23930	Decal, Guaranteed Delivery	1	Optional Item
9	22175	Lens, Escutcheon, GFM, Ver. 2	1	
10	24616	Escutcheon, Plastic, Epoch	1	
—	24623	Escutcheon/Keypad Assy.		Includes Escutcheon, Lighted Keypad & Buttons and Display Lens
11	22177	Button, 0.90" Dia. Round, Escutcheon	12	12 Key Escutcheon
12	25688	Assembly, Lighted Keypad	1	12 Key Escutcheon
	25678	Assembly, Keypad, Epoch LED	1	
13	22184-01	DBV Cover Panel, Gray	2	Optional Item
14	25222	Assy., Foamed Door, Snack, Epoch (35")	1	Contact AMS for your application.
	25106	Assy., Foamed Door, Snack, Epoch-ADA (35")		
	25220	Assy., Foamed Door, Snack, Epoch (39")		
	25083	Assy., Foamed Door, Snack, Epoch-ADA (39")		
15	21703	Assy., Top Hinge, 3/16"	1	
16	21704	Assy., Bottom Hinge, 3/16"	1	

DOOR, SENSOR SYSTEM AND HOPPER ILLUSTRATION

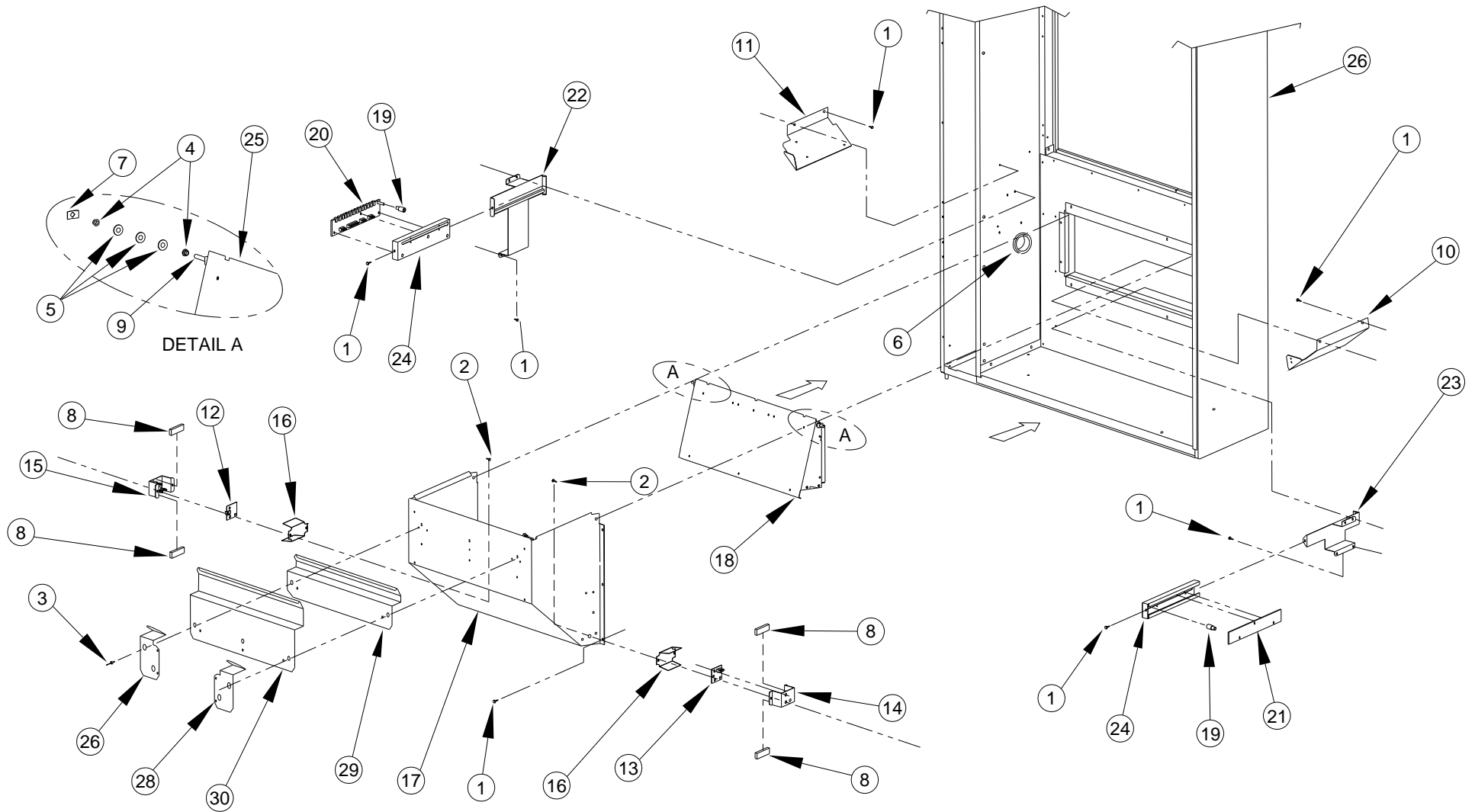

DOOR, SENSOR SYSTEM AND HOPPER PARTS LIST

ITEM	PART NO.	PART DESCRIPTION	QTY.	NOTES
1	3000	Screw, TEK 8-18	24	
2	3002-04	Screw, Machine, Type F, 8-32	4	¾" Long, Self-Tap, Phillips, Round Head
3	3009-04	Rivet, Pop, Steel, 1/8 x 1/4 Grip	8	
4	3015	Bearing, Nyliner Snap-In	4	
5	3017-10	Washer, Flat Steel, SAE Std. , #10 Screw 7/32 X ½	6	
6	3025-24	Grommet, Rubber, 1-1/2 ID x (1-3/4 OD X .062 Groove)	1	Harness Pass-Through
7	3113	Pushnut, 3/16" Stud	2	
8	3237	Tape, 3/8" X 1/4" Urethane Foam	4	1-5/8" Long Each Piece
9	20409	Vend Door, Shaft (35")	1	
	20108	Vend Door, Shaft (39")	1	
10	21460	Product Kicker, Left w/out flange	1	(Left Hand When Facing Front Of Door)
	21457	Product Kicker, Left		
11	21461	Product Kicker Right w/out flange	1	(Right Hand When Facing Front Of Door)
	21458	Product Kicker Right		
12	21385	Detector, Product Sensor	1	
13	21386	Emitter, Product Sensor	1	
14	21442	Assembly, Product Sensor Emitter Bracket	1	
15	21443	Assembly, Product Sensor Detector Bracket	1	
16	21798	Lens, Product Sensor Bracket	2	
17	22262	Assembly, Vend Hopper, (35")	1	
	22384	Assembly, Vend Hopper, 1.5 CU. FT. Hopper (39")		
18	22328	Assembly, Vend Door, Snack (35")	1	
	22327	Assembly, Vend Door, Snack, 1.5 CU. FT. Hopper (39")		
19	26051	Black Spacer		
20	26520	Sensor Board, Primary, Ver. 5	1	Add (1) Sensor Extension 26051
21	26521	Sensor Board, Secondary, Ver. 5	1	Add (1) Sensor Extension 26051
22	24970	Assembly, Primary Delivery Sensor Bracket, Epoch	1	
23	22126	Assembly, Secondary Delivery Sensor Bracket	1	
24	22128	Assembly, Secondary Delivery Sensor Cover	1	
25	22130	Assembly, Primary Delivery Sensor Cover	1	

ITEM	PART NO.	PART DESCRIPTION	QTY.	NOTES
26	25222	Assy., Foamed Door, Snack, Epoch (35")	1	Contact AMS for your application.
	25106	Assy., Foamed Door, Snack, Epoch-ADA (35")		
	25220	Assy., Foamed Door, Snack, Epoch (39")		
	25083	Assy., Foamed Door, Snack, Epoch-ADA (39")		
27	22387	Deflector Plate, 1.5" Helix Tray, RH (39" Only)	1	Rivet to Hopper For 1.5" Helix Tray (39")
28	22387-01	Deflector Plate, 1.5" Helix Tray, LH (39" Only)	1	
29	22388	Deflector Plate, 2.25" Height, 1-1/8 CU. FT. Hopper (35")	1	Rivet to Hopper in place of 22387 or 22389
	22390	Deflector Plate, 2.25" Height, 1.5 CU. FT. Hopper (39")		
30	22389	Deflector Plate, 2.71" Height, 1-1/8 CU. FT. Hopper (35")	1	Rivet to Hopper in place of 22388 or 22387
	22386	Deflector Plate, 2.71" Height, 1.5 CU. FT. Hopper (39")		

NOTE: The product sensor option may not have been contracted for nor installed on your vendor.

THIS PAGE INTENTIONALLY LEFT BLANK

DOOR WITH OPTIONAL TRIM AND FINISH PARTS ILLUSTRATION

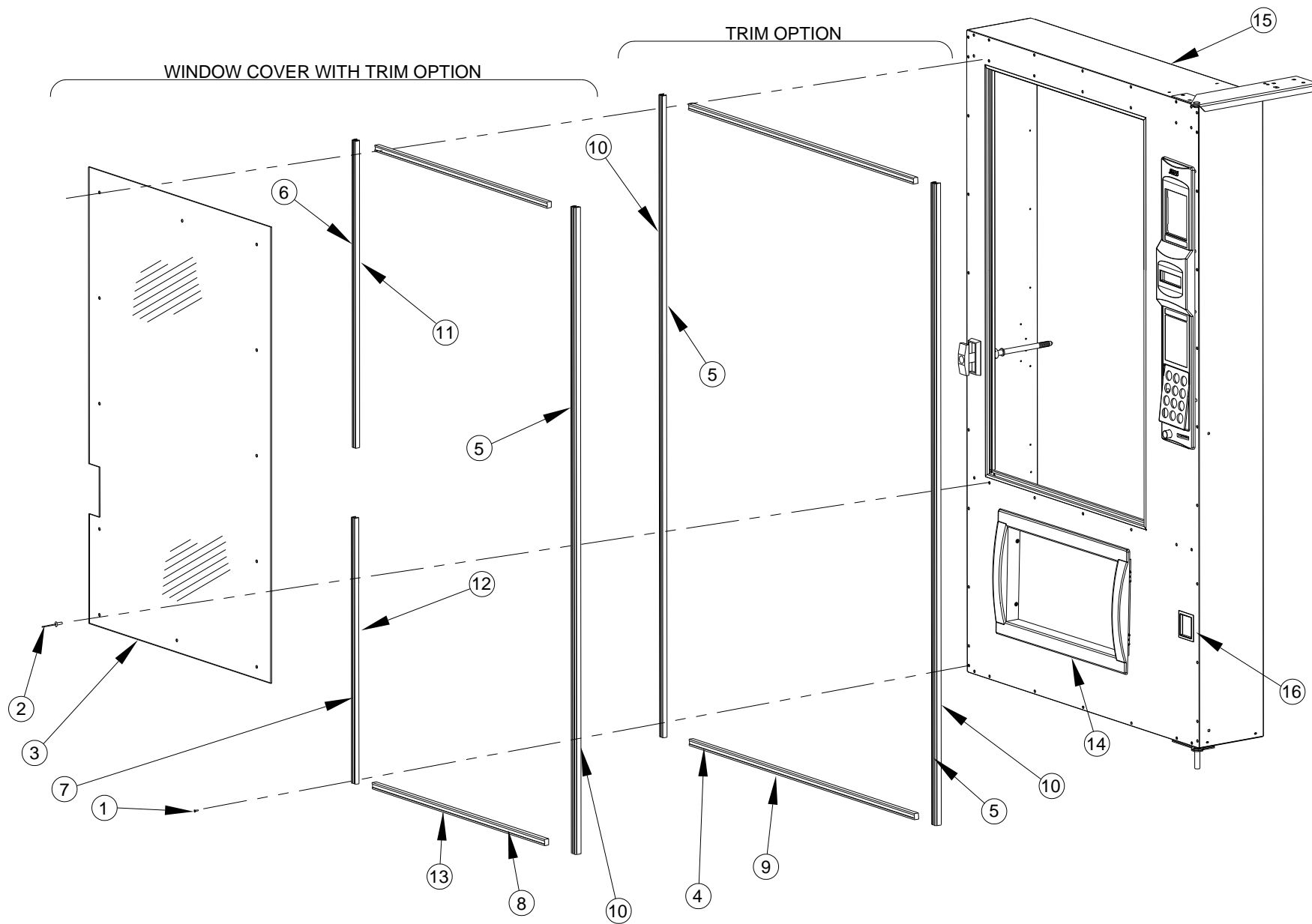

DOOR WITH OPTIONAL TRIM AND FINISH PARTS LIST

ITEM	PART NO.	PART NAME	QTY.	NOTES
1	3000	Screw, Sheet metal, TEK 8-18	28	For Securing Trim
2	3172-02	Rivet, Aluminum, ¼" Diameter, Natural (1/4" Grip)	15	For Securing Window Covers
3	-----	Window Cover, Polycarbonate (35")	1	Contact AMS for your application
	-----	Window Cover, Polycarbonate (39")		
4	21535-02	Trim, Plastic Insert, For Recessed Base (31.93") (35")	2	Snaps into Trim Base
	21535-01	Trim, Plastic Insert, For Recessed Base (37.25") (39")		
5	21535-03	Trim, Plastic Insert, For Recessed Base (65.38")	2	Snaps into Trim Base
6	21535-06	Trim, Plastic Insert, For Recessed Base (30.2")	1	Snaps into Trim Base
7	21535-07	Trim, Plastic Insert, For Recessed Base (29.4")	1	Snaps into Trim Base
8	21535-08	Trim, Plastic Insert, For Recessed Base (23.9") (35")	2	Snaps into Trim Base
	21535-15	Trim, Plastic Insert, For Recessed Base (29.68") (39")		
9	21612-02	Recessed Trim Base With Holes, Painted (35")	2	Black Paint Finish
	21612-01	Recessed Trim Base With Holes, Painted (39")		
10	21612-03	Recessed Trim Base With Holes, Painted	2	Black Paint Finish
11	21612-06	Recessed Trim Base With Holes, Painted	1	Black Paint Finish
12	21612-07	Recessed Trim Base With Holes, Painted	1	Black Paint Finish
13	21612-08	Recessed Trim Base With Holes, Painted (35")	2	Black Paint Finish
	21612-15	Recessed Trim Base With Holes, Painted (39")		
14	25080	Trim, Vend Eyelet	1	
15	25222	Assy., Foamed Door, Snack, Epoch (35")	1	Contact AMS for your application.
	25106	Assy., Foamed Door, Snack, Epoch-ADA (35")		
	25220	Assy., Foamed Door, Snack, Epoch (39")		
	25083	Assy., Foamed Door, Snack, Epoch-ADA (39")		
16	23372	Trim, Plastic Coin Cup	1	
	23372-01	Trim, Plastic Coin Cup, Gray	1	

NOTE: Trim Packages, Window Cover Packages and other options contracted for and installed at AMS may not apply to your vendor.

POS DISPLAY ILLUSTRATION

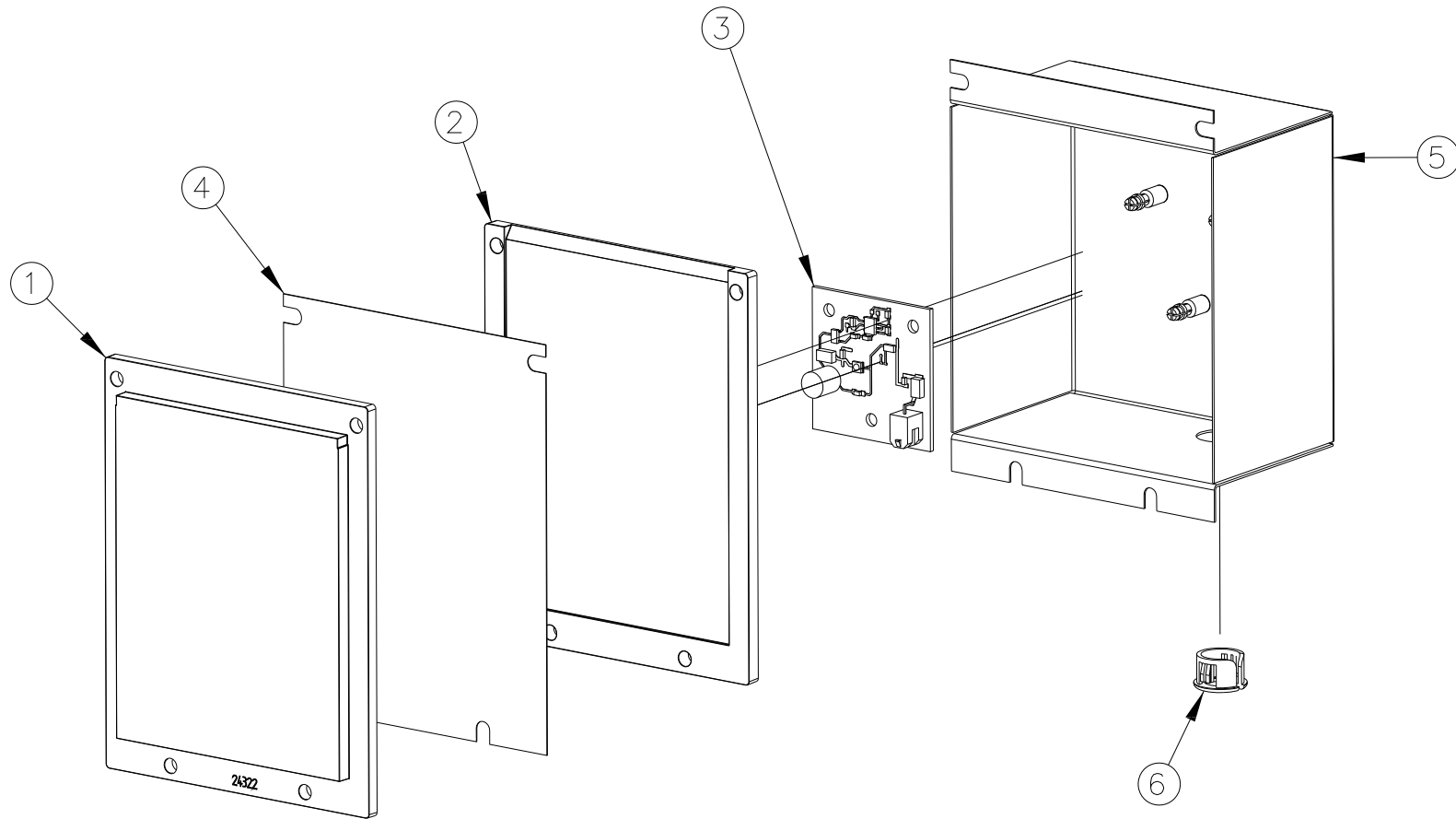

POS DISPLAY PARTS LIST

ITEM	PART NO.	PART DESCRIPTION	NOTES
1	24322	POS Display Insert	
2	24323	POS Display Diffuser	
3	24329	LED Board	
4	24767	POS Display Card (AMS)	ENGLISH
	24768	POS Display Card (IAMS)	SPANISH
5	24339	Lightbox Assembly	
6	3029-02	Bushing	

ELECTRICAL HARNESS ILLUSTRATIONS

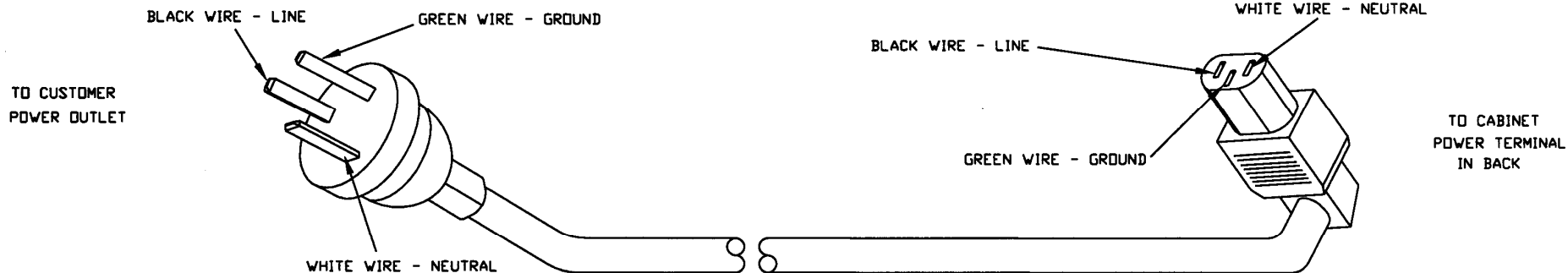

3173, POWER CORD, AUSTRALIA

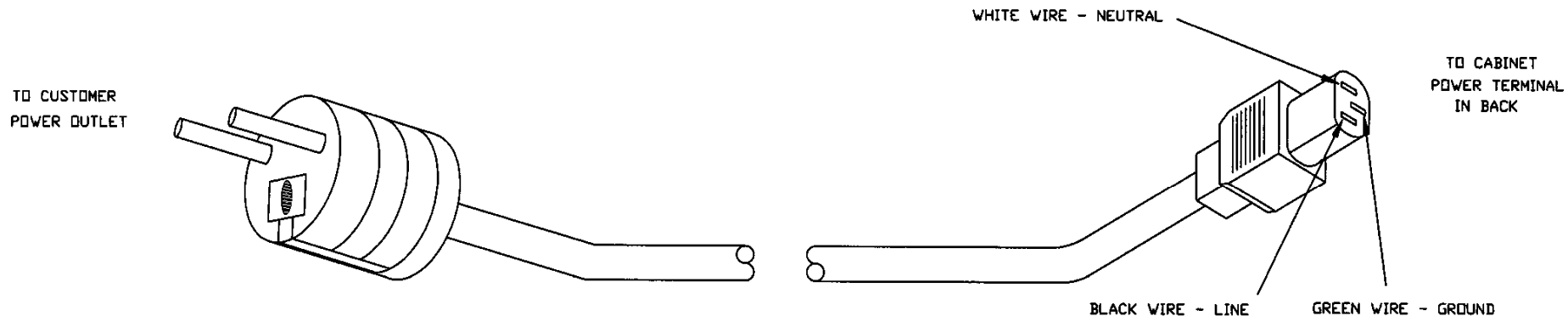

3193, POWER CORD, CONTINENTAL EUROPE

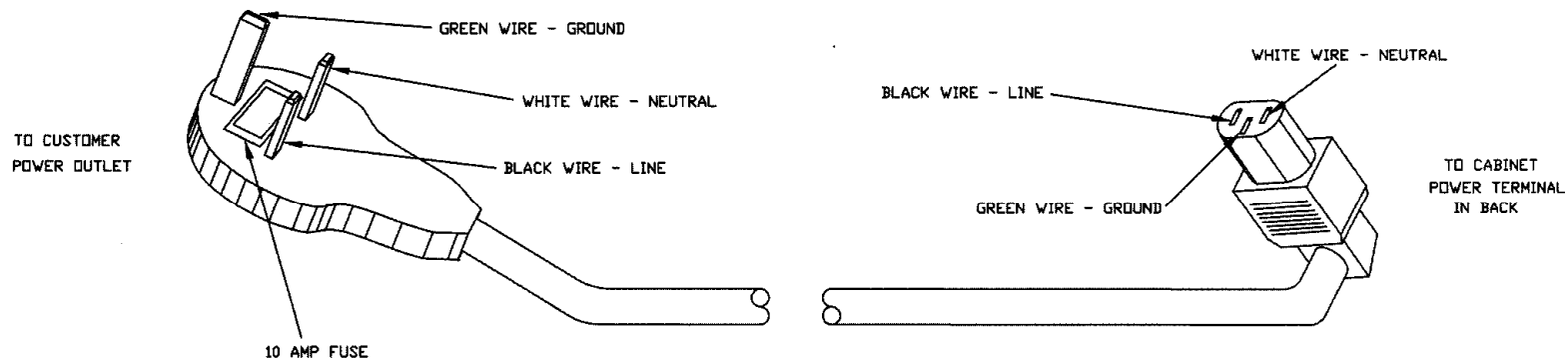

3194, POWER CORD, U.K. & IRELAND

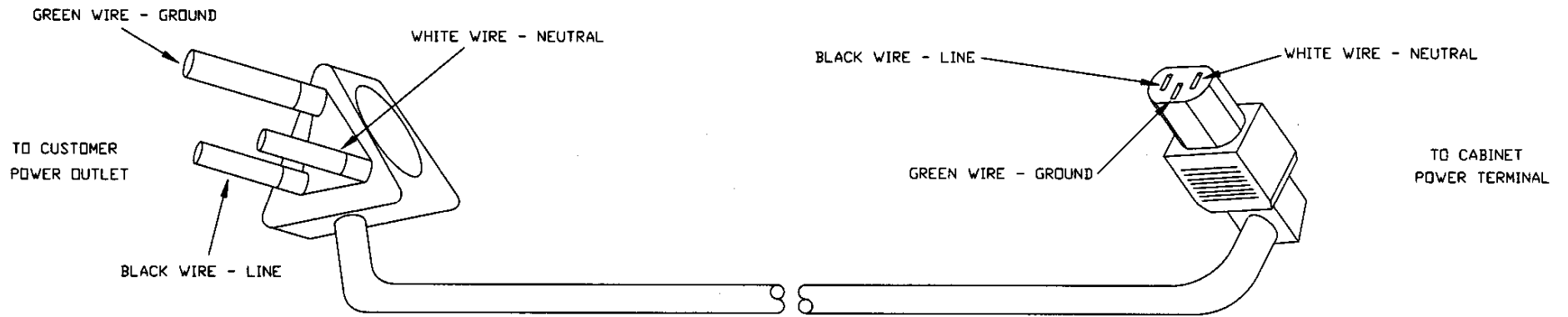

3208 POWER CORD, INDIA AND SOUTH AFRICA

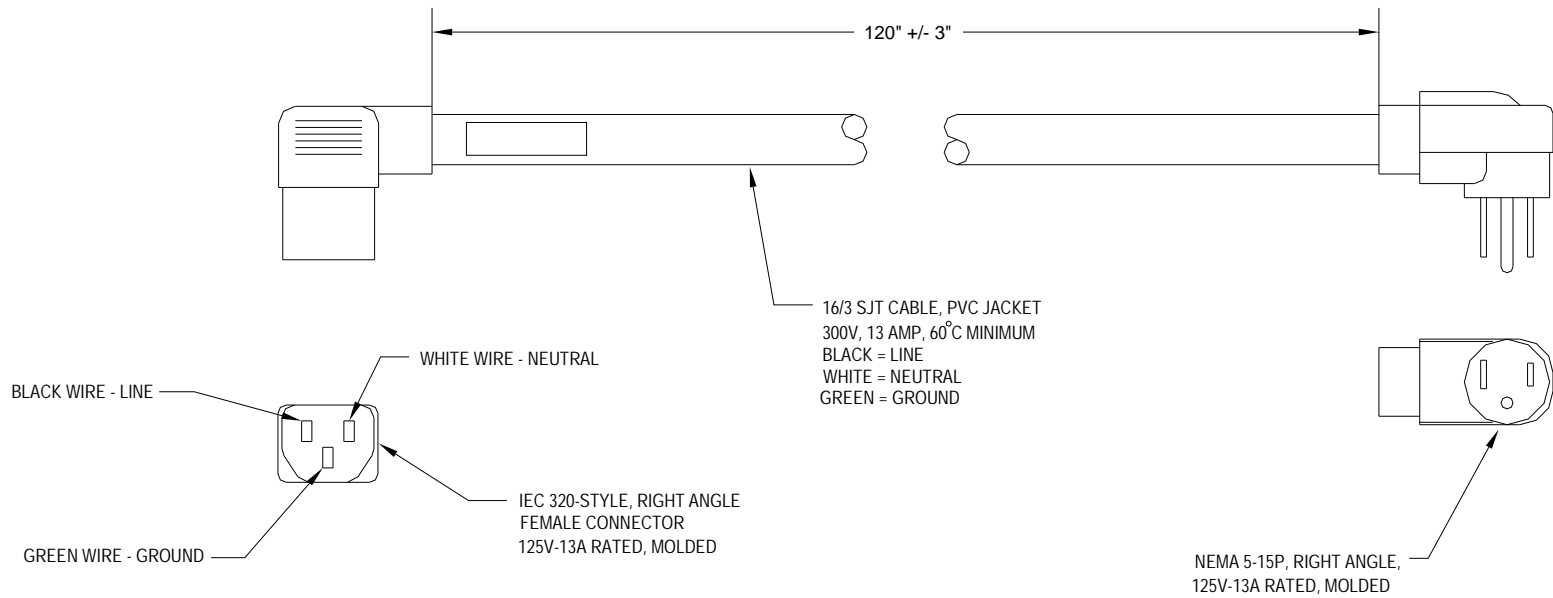

20142, POWER CORD ASSEMBLY, 115V DOMESTIC

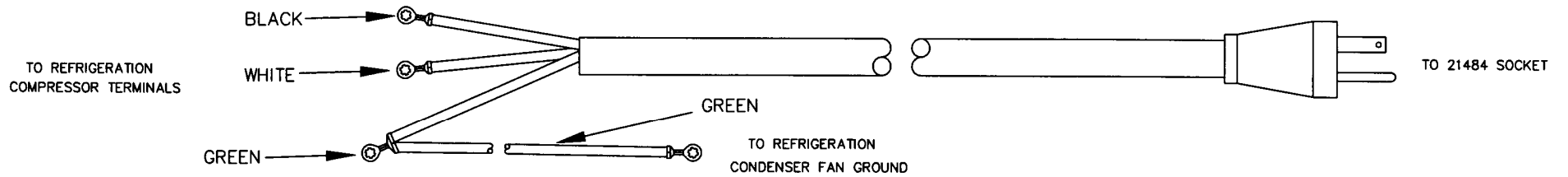

20144, HARNESS, REFRIGERATION

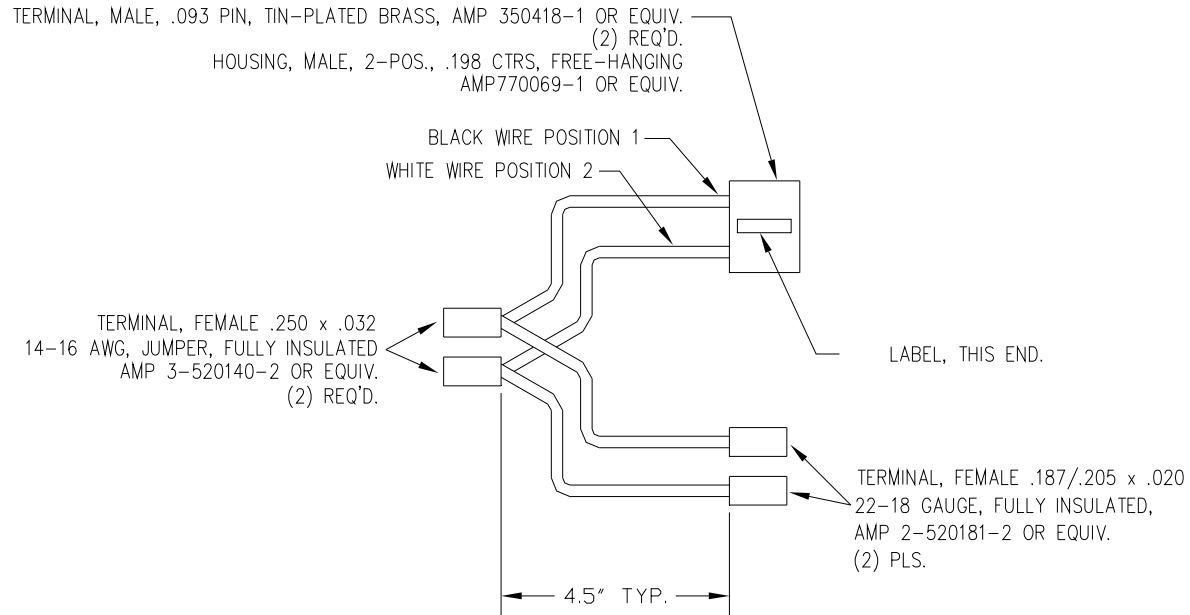

20149, HARNESS, BALLAST/TRANSFORMER LINE

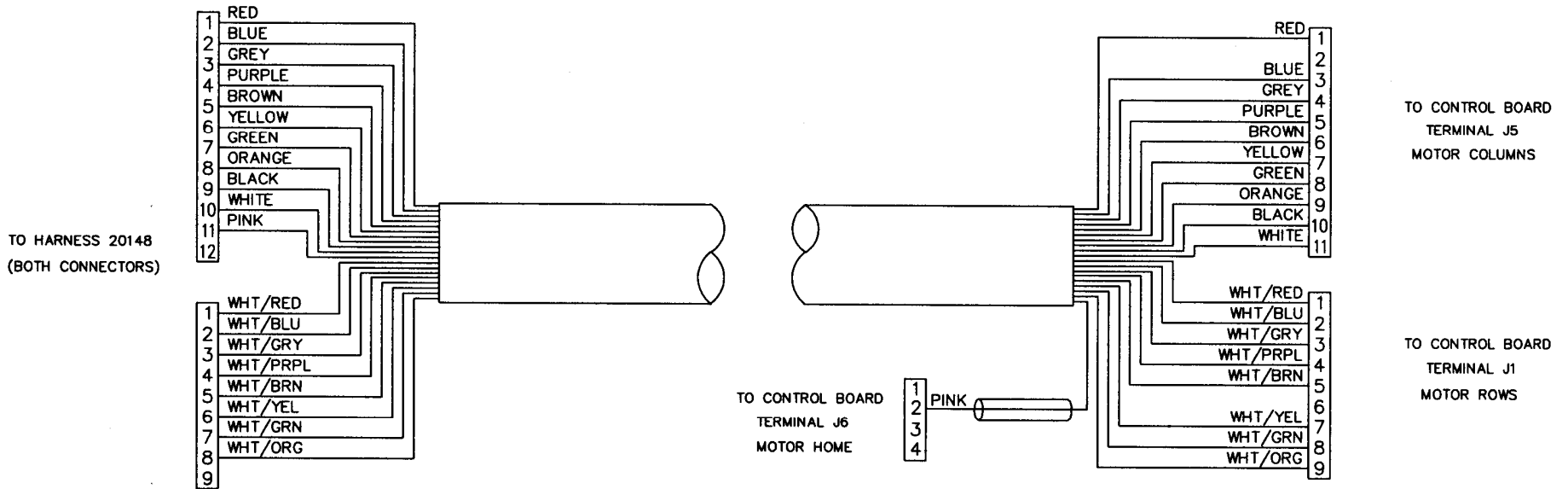

20146, HARNESS, DOOR MOTORS

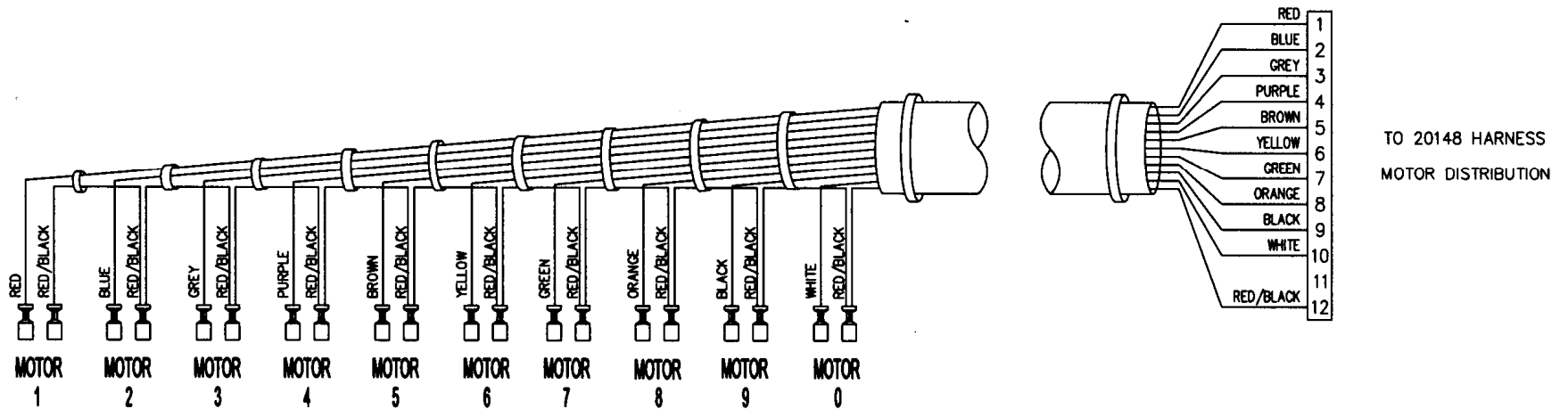

20147, HARNESS, TRAY, 10 COLUMN

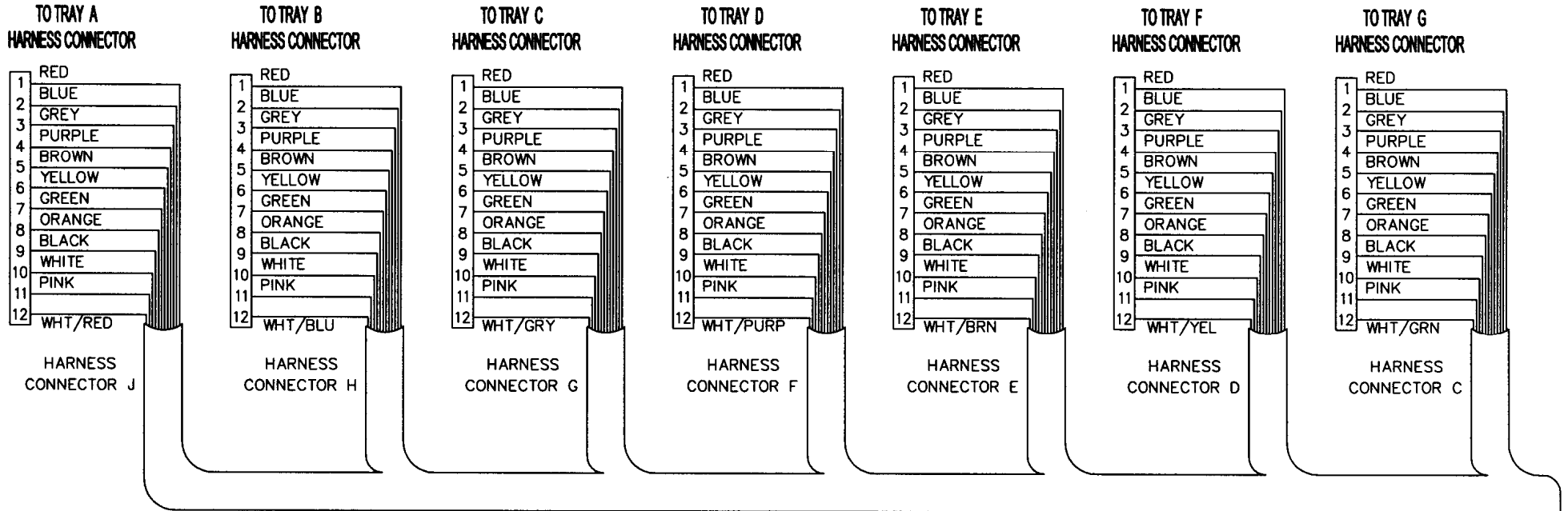

(CONNECTOR A IS JUMPERED TO ALL CONNECTORS TO TRAYS, PINS 1 -11)

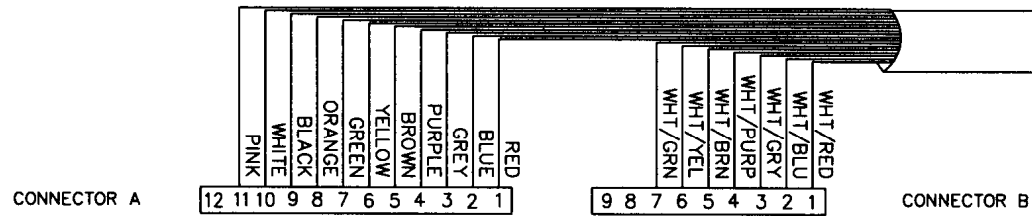

CONNECTOR A AND B TO 20146 HARNESS, DOOR MOTOR

20148, HARNESS, MOTOR DISTRIBUTION

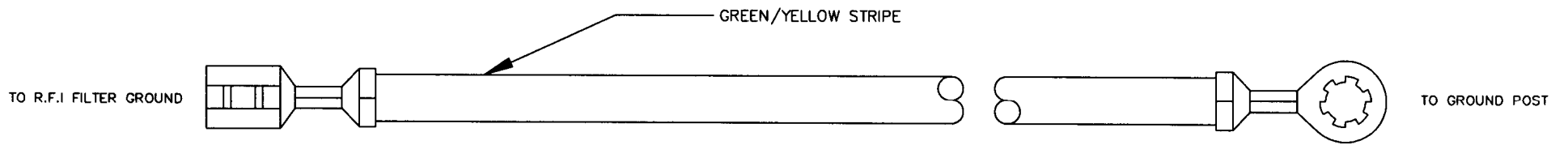

20154, HARNESS, R.F.I. FILTER GROUND

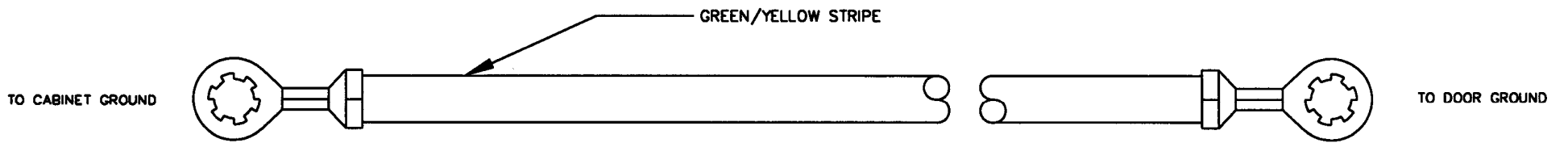

20156-01, HARNESS, GROUND

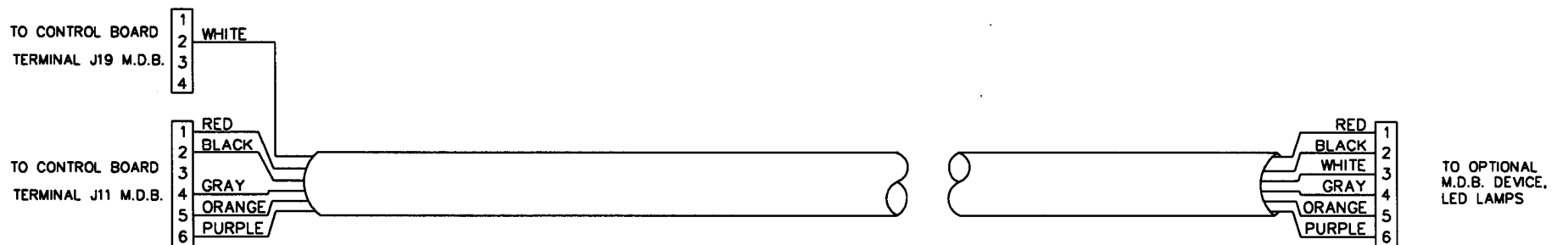

20158, HARNESS, MULTI-DROP BUS

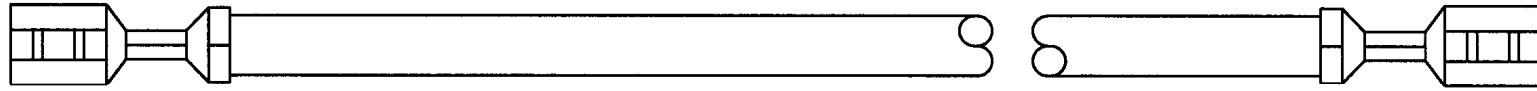

20648 JUMPER WIRE, 18 AWG X 3', FEMALE / FEMALE

TO 21591 HARNESS, POWER
AND REFRIGERATION RELAY,
LEFT SIDE DOOR SWITCH

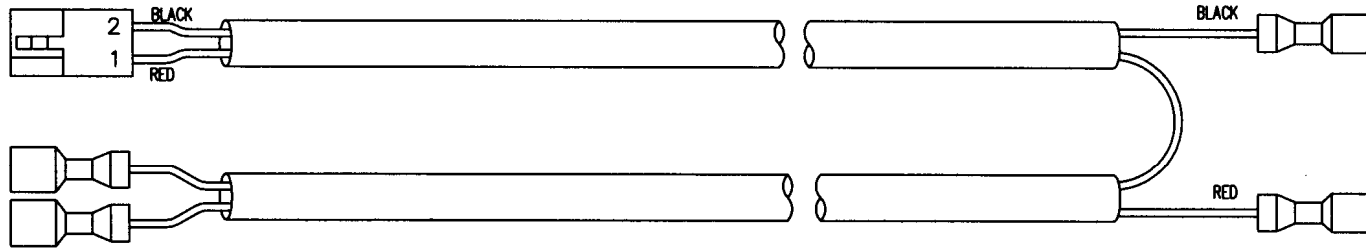

TO FUSE HOLDER

TO TRANSFORMER
24 VAC SECONDARY

20701, HARNESS, TRANSFORMER AND FUSE

TO 21591, HARNESS,
CONTROL POWER AND
REFRIGERATION RELAY,
LEFT SIDE DOOR SWITCH

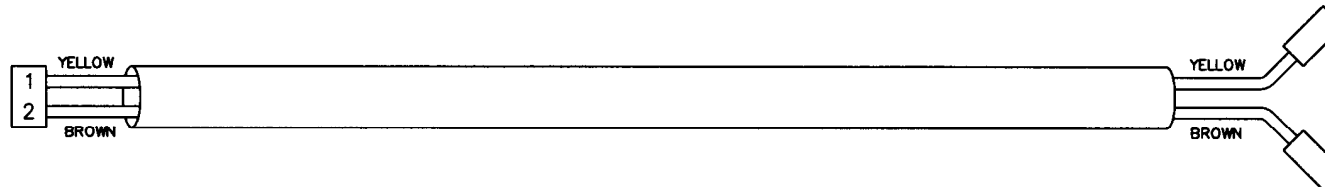

TO CHILLER RELAY
COIL SIDE

21405, HARNESS, REFRIGERATION RELAY, T9A SERIES

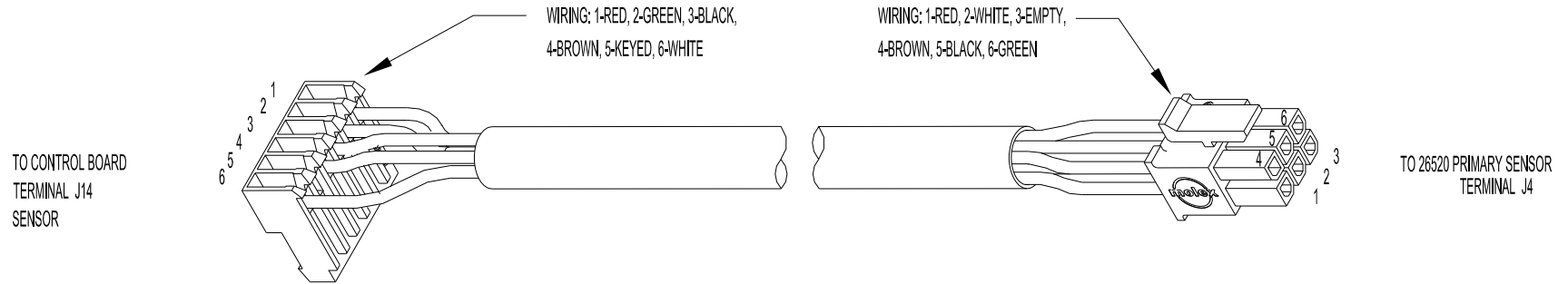

21425 HARNESS, DELIVERY SENSOR DETECTOR/CONTROL

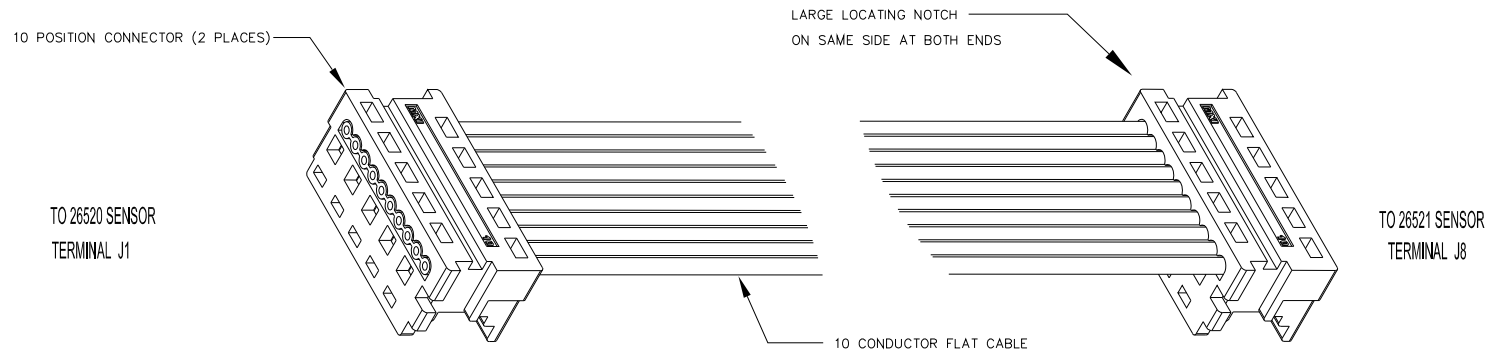

21426 HARNESS, DELIVERY SENSOR DETECTOR/EMITTER

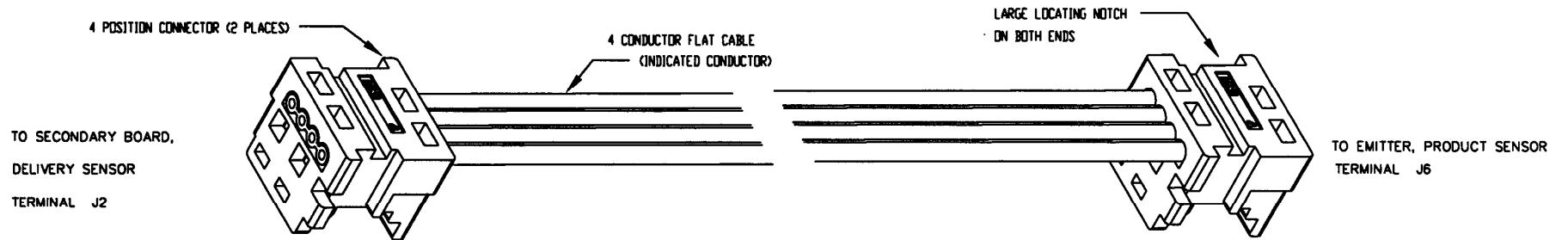

21427 HARNESS, PRODUCT SENSOR EMITTER, (OPTIONAL)

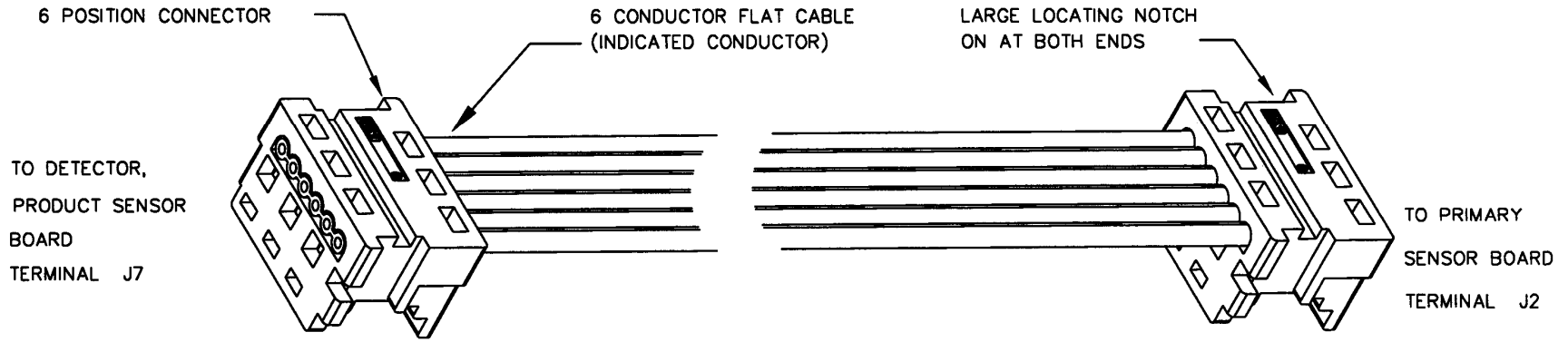

21428, HARNESS, PRODUCT SENSOR DETECTOR (OPTIONAL)

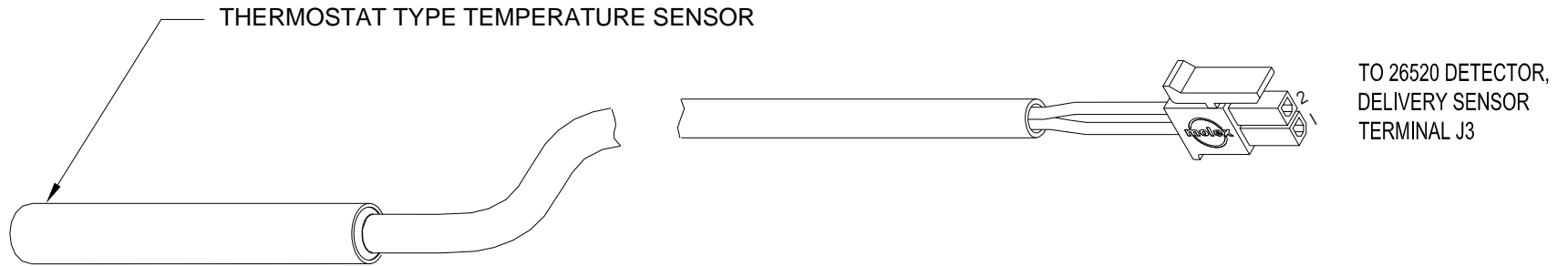

21468 TEMPERATURE SENSOR

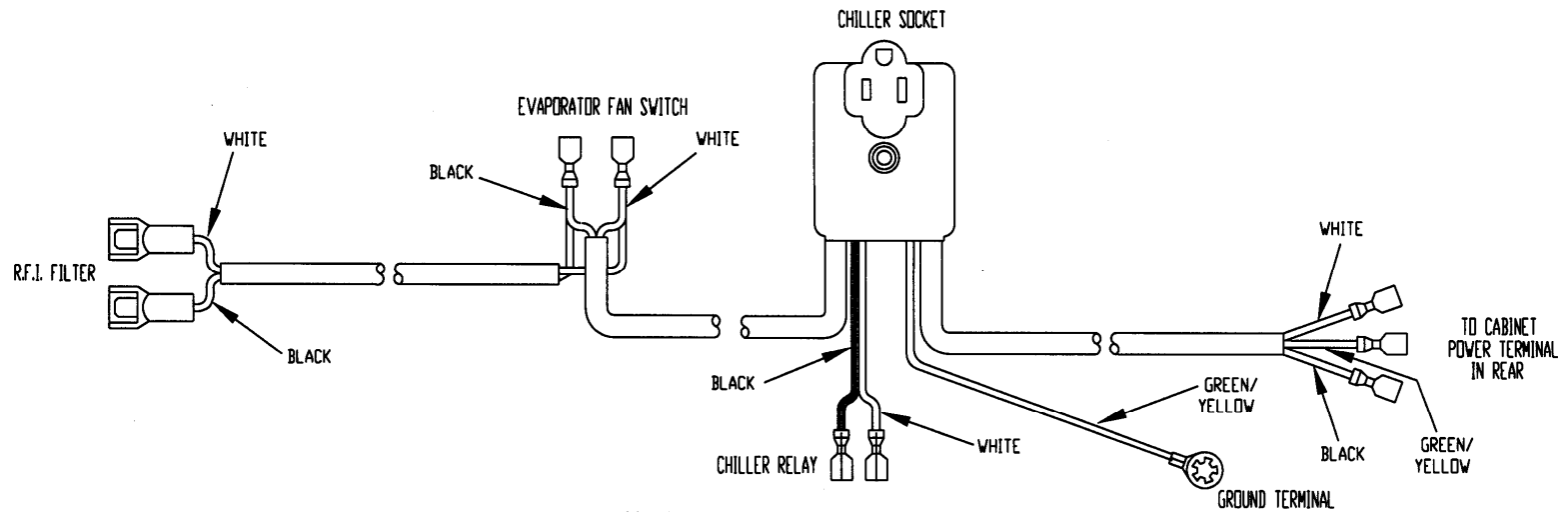

21484, HARNESS, POWER DISTRIBUTION, INTEGRAL SOCKET, ON/OFF SWITCH

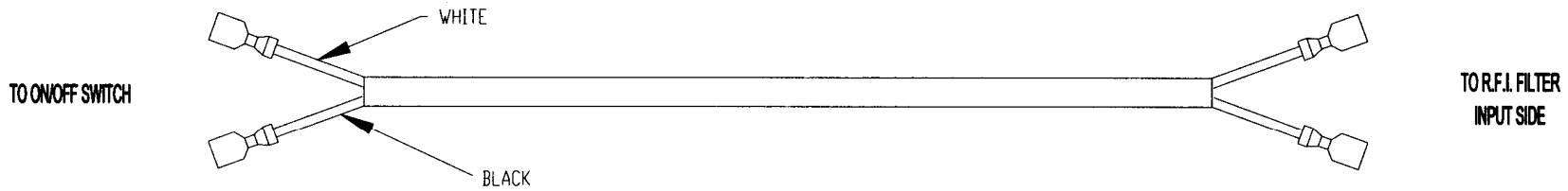

21485, HARNESS, ON/OFF SWITCH

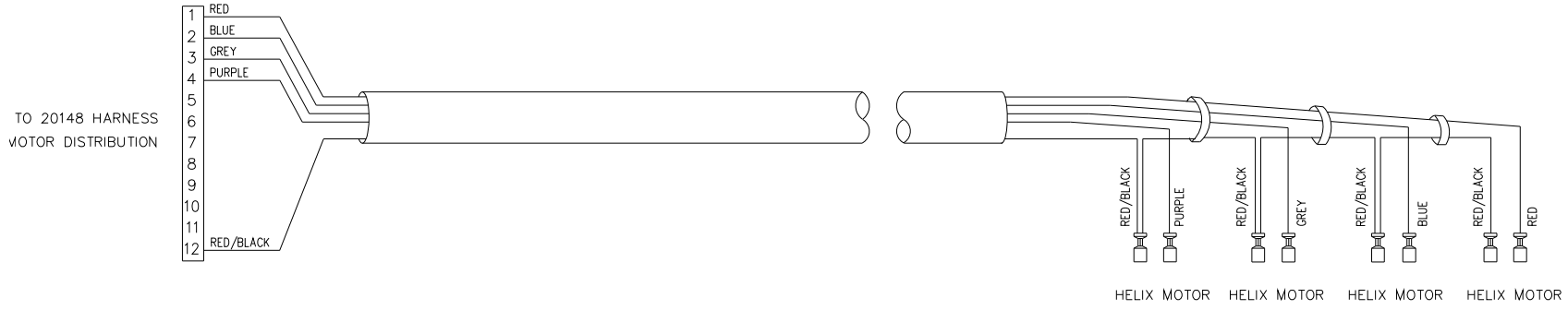

21584, HARNESS, 1.5" HELIX TRAY (OPTIONAL)

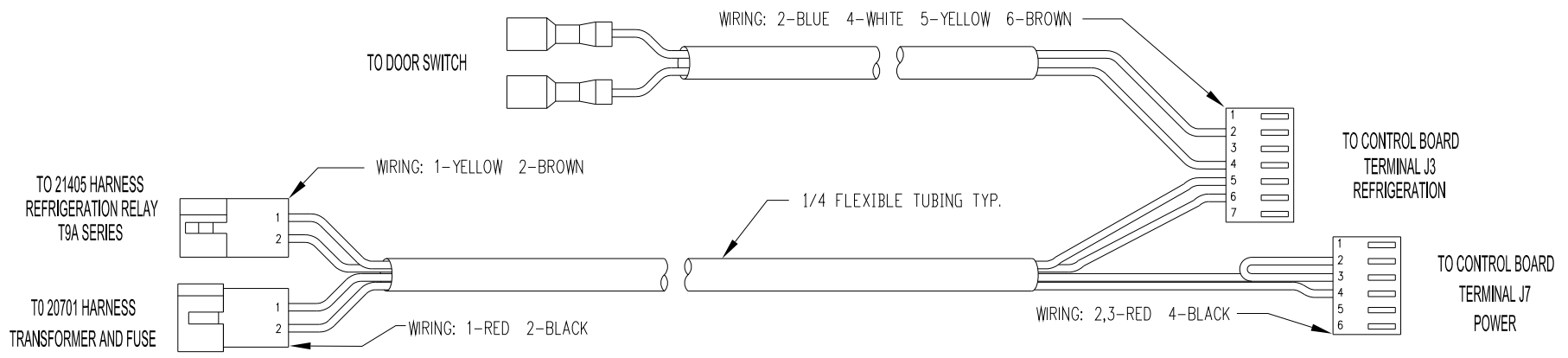

21590, HARNESS, CONTROL POWER AND REFRIGERATION RELAY

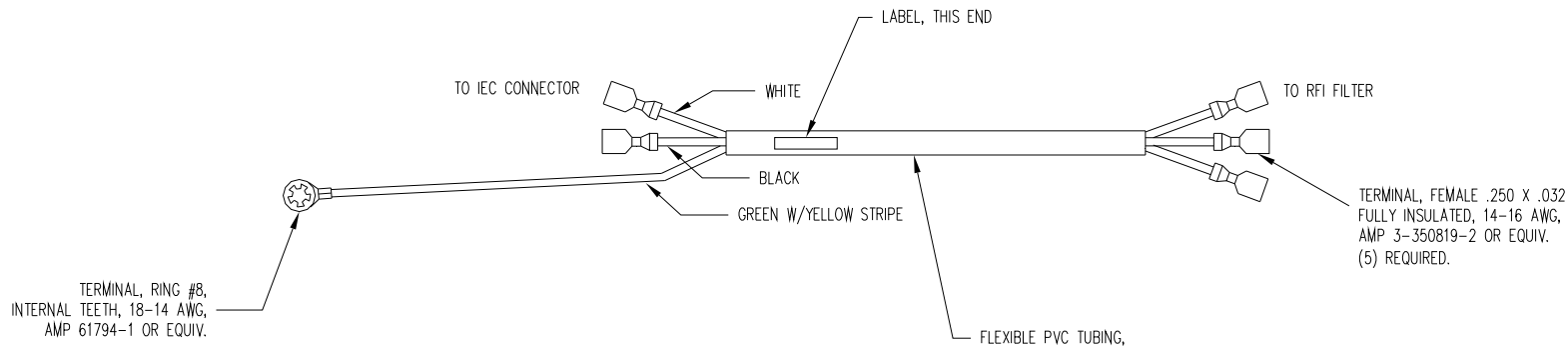
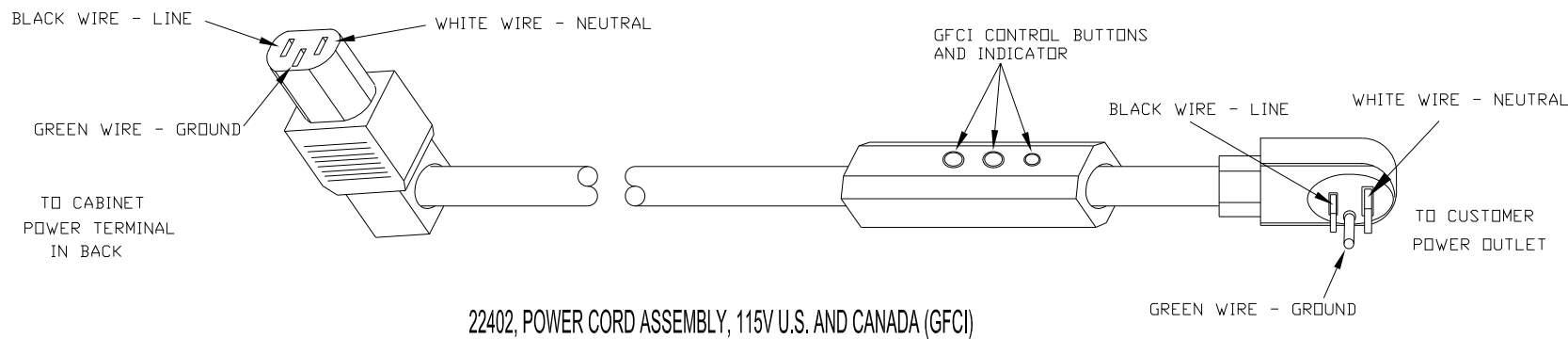
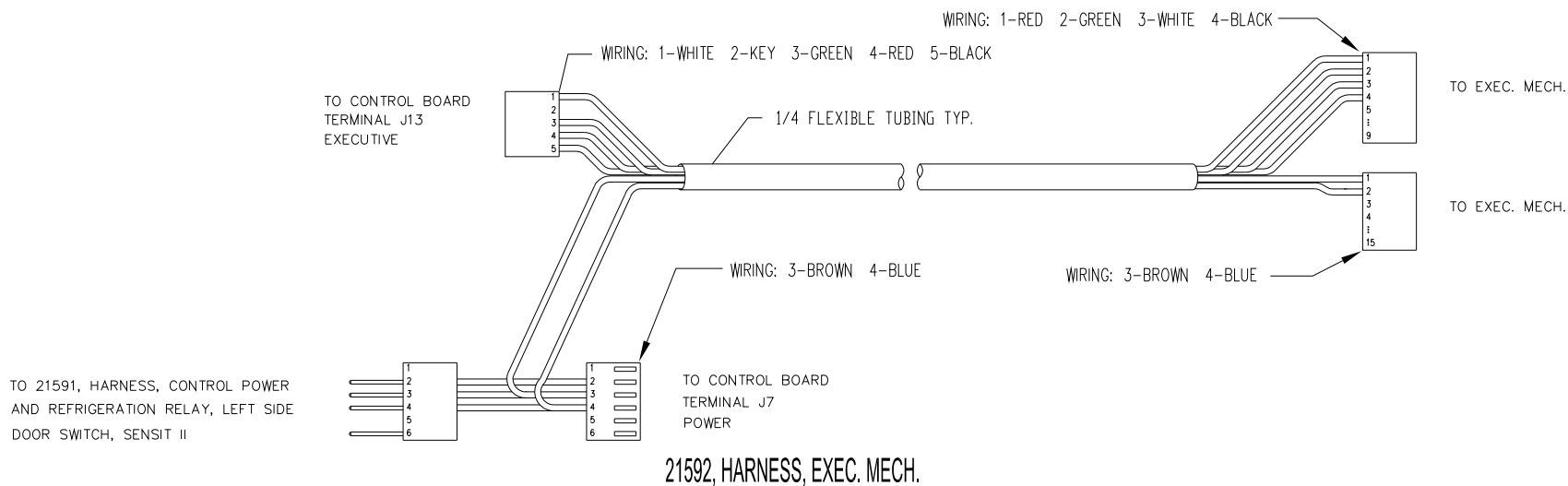

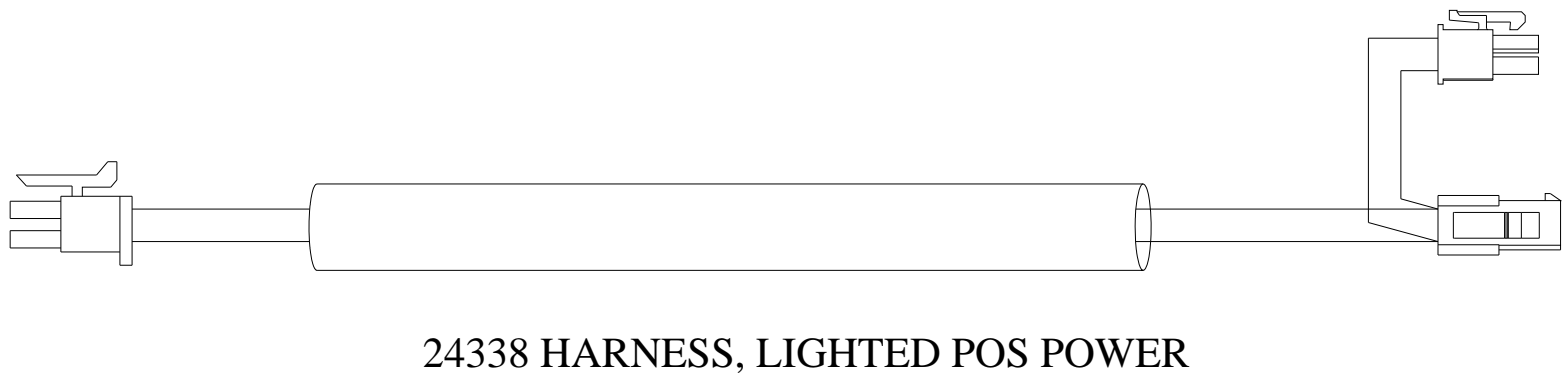
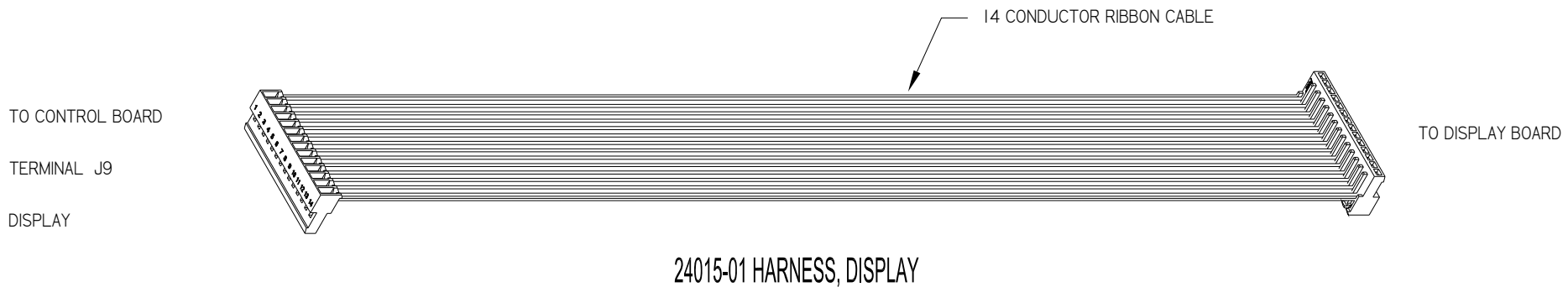
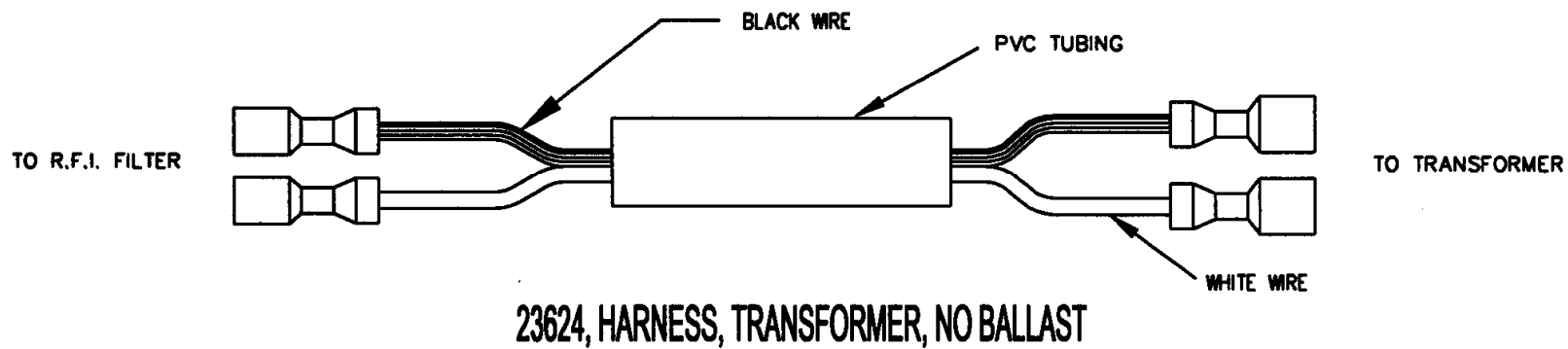

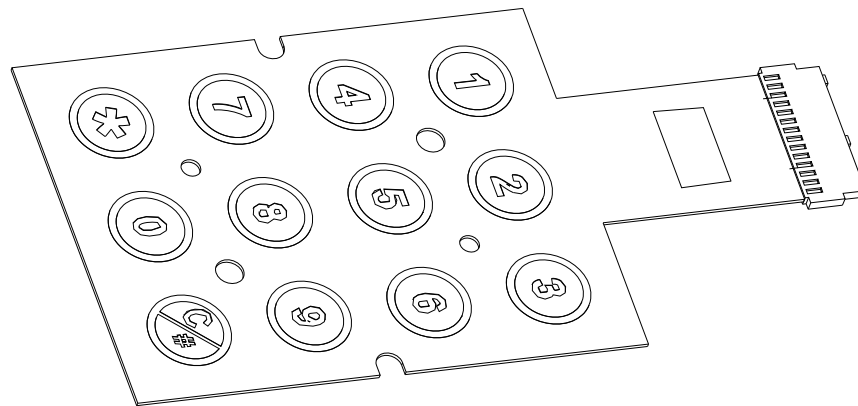

25688 ASSEMBLY, LIGHTED KEYPAD

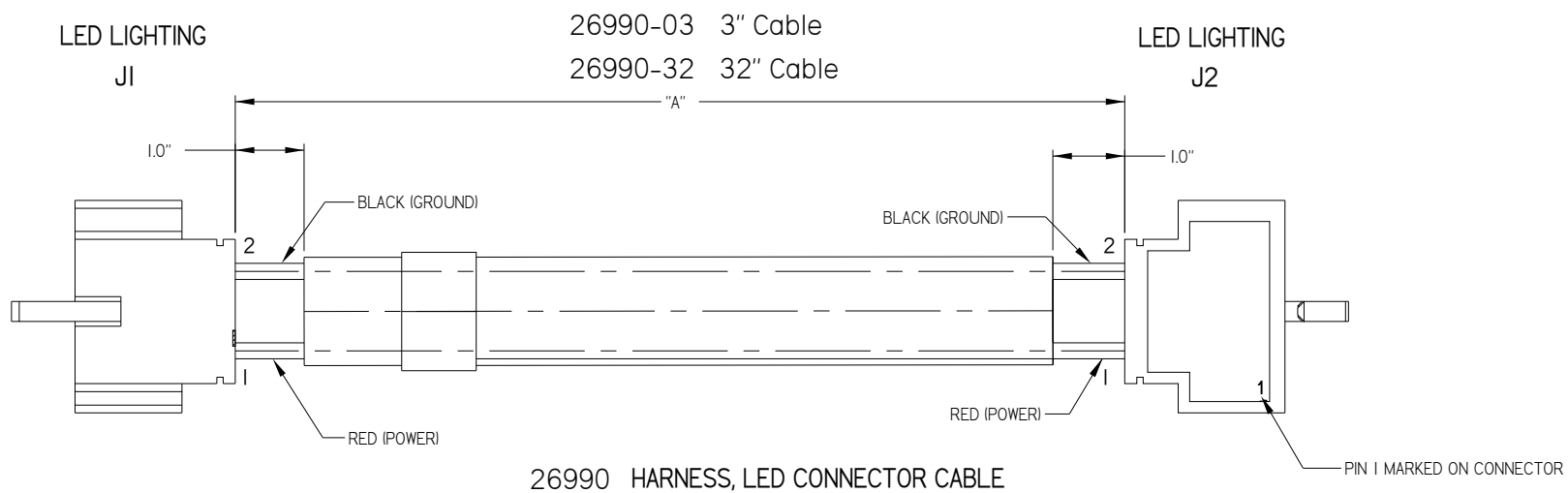

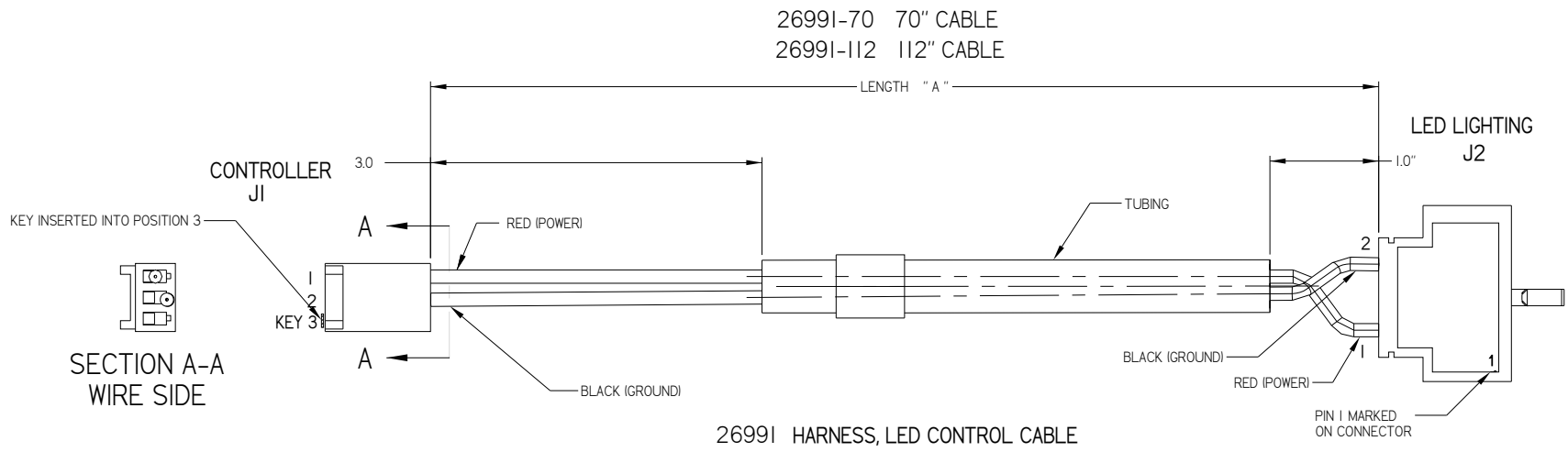

ELECTRICAL HARNESS PARTS LIST

PART NO.	PART DESCRIPTION	QTY.	NOTES
3173	Power Cord, Australia	1	
3193	Power Cord, Continental Europe	1	
3194	Power Cord, U.K. and Ireland	1	
3208	Power Cord, India and South Africa	1	
20142	Power Cord Assembly, 115V Domestic	1	
20144	Harness, Refrigeration	1	For Chiller Power
20146	Harness, Door Motors	1	
20147	Harness, Tray, 10 Column	1	Use For 5 Column Tray
20148	Harness, Motor Distribution	1	
20149	Harness, Ballast/Transformer Line	1	
20154	Harness, R.F.I. Filter Ground	1	
20156-01	Harness, Ground	1	
20158	Harness, Multi-Drop Bus	1	Use For Both SII and S3
20648	Jumper Wire	2	Australia 240V Single
20701	Harness, Transformer and Fuse	1	
21405	Harness, Refrigeration Relay T9A	1	
21425	Harness, Delivery Sensor Detector/Control	1	Primary to Control Board
21426	Harness, Delivery Sensor Detector/Emitter	1	Secondary to Primary Board
21427	Harness, Product Sensor Emitter	1	Secondary to Emitter Board (Optional)
21428	Harness, Product Sensor Detector	1	Primary to Detector Board (Optional)

PART NO.	PART DESCRIPTION	QTY.	NOTES
21468	Temperature Sensor, and Harness	1	Integral to Sensor, for Chiller
21484	Harness, Power Distribution, Integral Socket	1	
21485	Harness, On/Off Switch	1	
21584	Harness, 1.5" Helix Tray	1	
21590	Harness, Control Power & Refrigeration Relay	1	
21592	Harness, Executive Mech. Connector	1	
22402	Power Cord Assembly, 115, US and Canada	1	With GFCI, Use in U.S. and Canada
23357	Power Input Harness Ambient	1	
23624	Harness, Transformer, No Ballast	1	Use with LED Lighting
24015	Harness, Display	1	
24338	Lighted POS Power Harness	1	
25688	Assembly, Lighted Keypad	1	
26990-03	Harness, LED Connector Cable, 3"	1	
26990-32	Harness, LED Connector Cable, 32"	1	
26991-70	Harness, LED Control Cable, 70"	1	
26991-112	Harness, LED Control Cable, 112"	1	

NOTE: Some assemblies, such as the keypad, are fabricated with the harness as a unit. These are replaceable only as a unit.
Some harness assemblies listed above are for options which may not have been contracted for and installed by AMS.

HELIX ILLUSTRATIONS

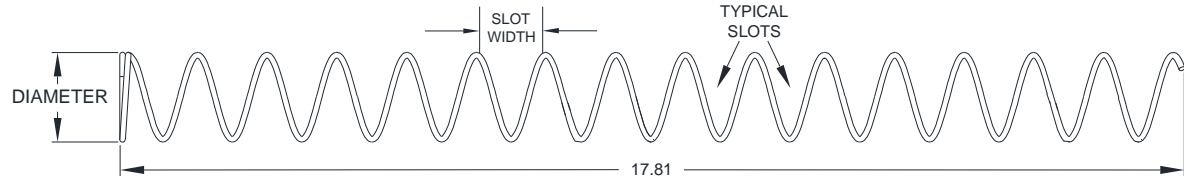

TYPICAL 1.5 HELIX TRAY SMALL HELIX

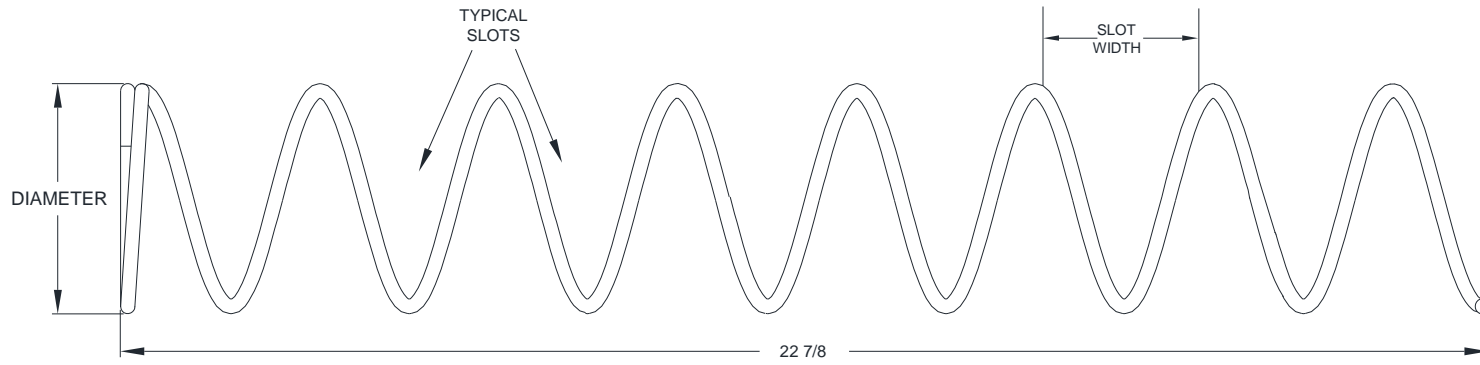

TYPICAL SMALL HELIX

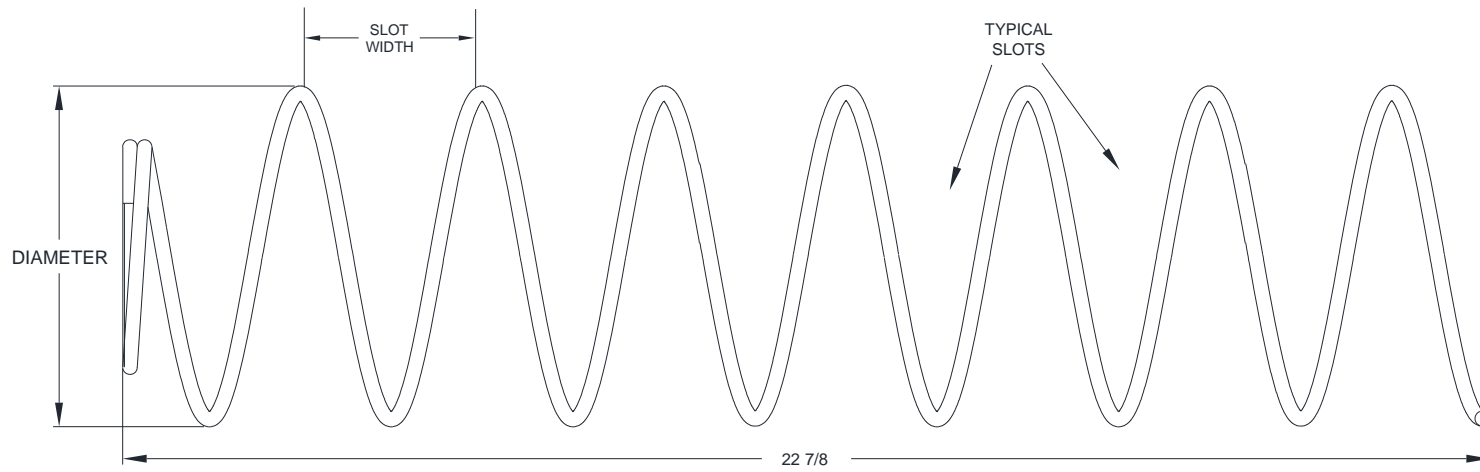

TYPICAL LARGE HELIX

HELIX PARTS LIST

PART NO.	HELIX DESCRIPTION *	SLOT (VEND) WIDTH	NUMBER OF SLOTS (PITCH)	HELIX OUTSIDE DIAMETER	TURNS	QTY. PER COLUMN	NOTES
20119-07	Helix, Small CW, Black	2 5/8	7	2.6	CW	1 Set	Use With 20120-07 As A Set
20120-07	Helix, Small CCW, Black	2 5/8	7	2.6	CCW	1 Set	
20119-10	Helix, Small CW, Black	1 7/8	10	2.6	CW	1 Set	Use With 20120-10 As A Set
20120-10	Helix, Small CCW, Black	1 7/8	10	2.6	CCW	1 Set	
20119-05	Helix, Small CW, Black	4	5	2.6	CW	1	
20119-09	Helix, Small CW, Black	2 1/4	9	2.6	CW	1	
20120-05	Helix, Small CW, Black	4	5	2.6	CCW	1	
20120-08	Helix, Small CCW, Black	2 1/2	8	2.6	CCW	1	
20120-09	Helix, Small CCW, Black	2 1/4	9	2.6	CCW	1	
20120-12	Helix, Small CCW, Black	1 7/8	12	2.6	CCW	1	
20120-15	Helix, Small CCW, Black	1 7/8	15	2.6	CCW	1	
20120-18	Helix, Small CCW, Black	1 7/8	18	2.6	CCW	1	
20120-24	Helix, Small CCW, Black	1 7/8	24	2.6	CCW	1	
20120-32	Helix, Small CCW, Black	1/2	32	2.6	CCW	1	
21207-15	Helix, 1.5", CCW, Black	1	15	1.5	CCW	1	Use in 1.5" Helix Tray
21207-25	Helix, 1.5", CCW, Black	9/16	25	1.5	CCW	1	Use in 1.5" Helix Tray
21336	Helix, 3", CCW, Black	3.5	6	3	CCW	1	Bottle Tray
21337	Helix, 3", CCW, Black	3.2	6	3	CCW	1	Bottle Tray

*Contact your distributor for special helix diameters and pitch.

*Contact AMS for your application.

PART NO.	HELIX DESCRIPTION *	SLOT (VEND) WIDTH	NUMBER OF SLOTS (PITCH)	HELIX OUTSIDE DIAMETER	TURNS	QTY. PER COLUMN	NOTES
21465-04	Helix, 3.75" CCW, Black	4 1/8	4	3.75	CCW	1	Large Diameter
21465-05	Helix, 3.75" CCW, Black	3 1/4	5	3.75	CCW	1	Large Diameter
21465-07	Helix, 3.75" CCW, Black	2 5/8	7	3.75	CCW	1	Large Diameter
21465-09	Helix, 3.75" CCW, Black	2	9	3.75	CCW	1	Large Diameter
21465-10	Helix, 3.75" CCW, Black	1 3/4	10	3.75	CCW	1	Large Diameter
21465-12	Helix, 3.75" CCW, Black	1 1/2	12	3.75	CCW	1	Large Diameter
21465-15	Helix, 3.75" CCW, Black	1 1/4	15	3.75	CCW	1	Large Diameter
23268-10	Helix, 1.5", CCW, Black	1 7/8	10	1.5	CCW	1	Use in 1.5" Helix Tray
23268-20	Helix, 1.5", CCW, Black	1	20	1.5	CCW	1	Use in 1.5" Helix Tray
23268-32	Helix, 1.5", CCW, Black	1/2	32	1.5	CCW	1	Use in 1.5" Helix Tray

*Contact your distributor for special helix diameters and pitch. Contact AMS for your application.

THIS PAGE INTENTIONALLY LEFT BLANK

1.5" HELIX TRAY ILLUSTRATION

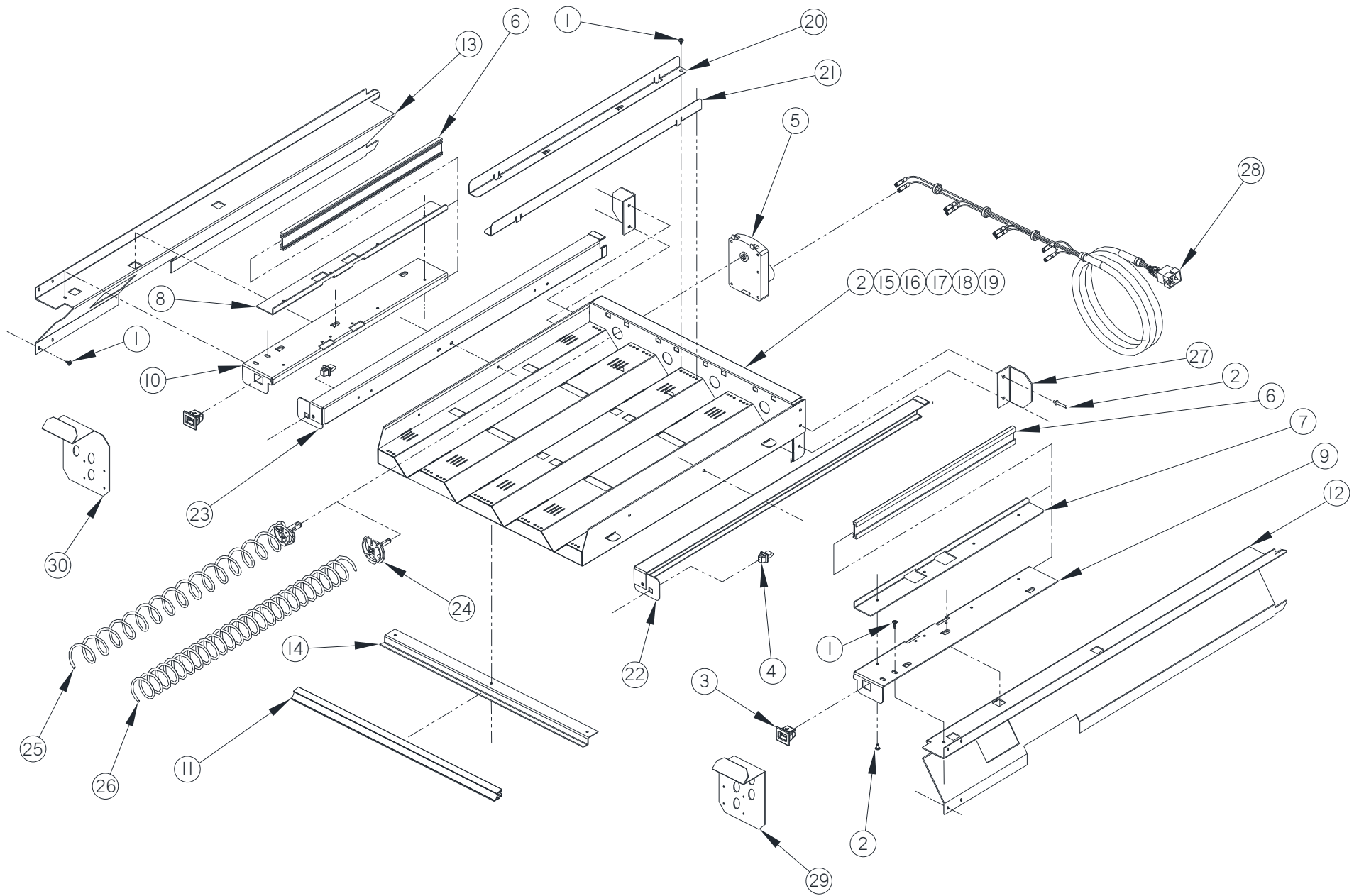

1.5" HELIX TRAY PARTS LIST

ITEM	PART NO.	PART DESCRIPTION	QTY.	NOTES
1	3000	Screw, TEK 8-18	18	
2	3009-02	Rivet, Pop, Steel, 1/8	34	
3	3246	Latch, Nylon, Gum and Mint	2	
4	3247	Strike, Nylon, Gum and Mint	2	
5	23007	Motor, Single Helix	4	
6	20236	Extrusion, Gum and Mint Rail	2	
7	20237	Extrusion Mount, Upper (Gum and Mint)(Right Side)	1	
8	20237-01	Extrusion Mount, Upper (Gum and Mint)(Left Side)	1	
9	20238	Extrusion Mount, Lower (Gum and Mint)(Right Side)	1	
10	20238-01	Extrusion Mount, Lower (Gum and Mint)(Left Side)	1	
11	20465-04	Extrusion, Price Marker, Reduced Height	1	
12	21046	Rail, Gum and Mint, Reduced Depth (35")(Right Side)	1	Rails To Fit Tray To 35" Cabinet
	20973	Rail, Gum and Mint, Reduced Depth (39")(Assy., Lighted Keypad Right Side)		Rails To Fit Tray To 39" Cabinet
13	21046-01	Rail, Gum and Mint, Reduced Depth (35")(Left Side)	1	Rails To Fit Tray To 35" Cabinet
	20973-01	Rail, Gum and Mint, Reduced Depth (39")(Left Side)		Rails To Fit Tray To 39" Cabinet
14	21196	Doubler, Tray 1.5" Helix Tray	1	Parts Are Factory Assembled As A Unit
15	21197	Tray Body, 1.5" Helix Tray	1	
16	21199	Tray Back, 1.5" Helix Tray	1	
17	21200	Tray Inner Side, 1.5" Helix Tray	2	
18	21201	Tray Inner Section, 1.5" Helix Tray	2	
19	21202	Tray Inner Mid Section, 1.5" Helix Tray	1	
20	21203	Divider, Tray, 1.5" Helix Tray, RH	4	
21	21203-01	Divider, Tray, 1.5" Helix Tray, LH	4	
22	21204	Tray Slide Channel, 1.5" Helix Tray, RH	1	
23	21204-01	Tray Slide Channel, 1.5" Helix Tray, LH	1	
24	21206	Helix Adapter, 1.5" Helix Tray	4	Tray is Equipped With Two of Each
25	21207-15	Helix, 1.5" Tray, Counterclockwise, Black	2	
26	21207-25	Helix, 1.5" Tray, Counterclockwise, Black	2	
27	21523	Bracket, Stop, 1.5" Helix Tray	2	
28	21584	Harness, 1.5" Helix Tray	1	
29	22387	Deflector, 1.5" Helix Tray, RH (39")		Use When 1.5" Tray Is Installed
30	22387-01	Deflector, 1.5" Helix Tray, LH, (39")		Use When 1.5" Tray Is Installed

NOTE: Tray also comes in scrolling price option. Contact your distributor for details.

UNIVERSAL (SNACK/CANDY/FOOD) TRAY ILLUSTRATION

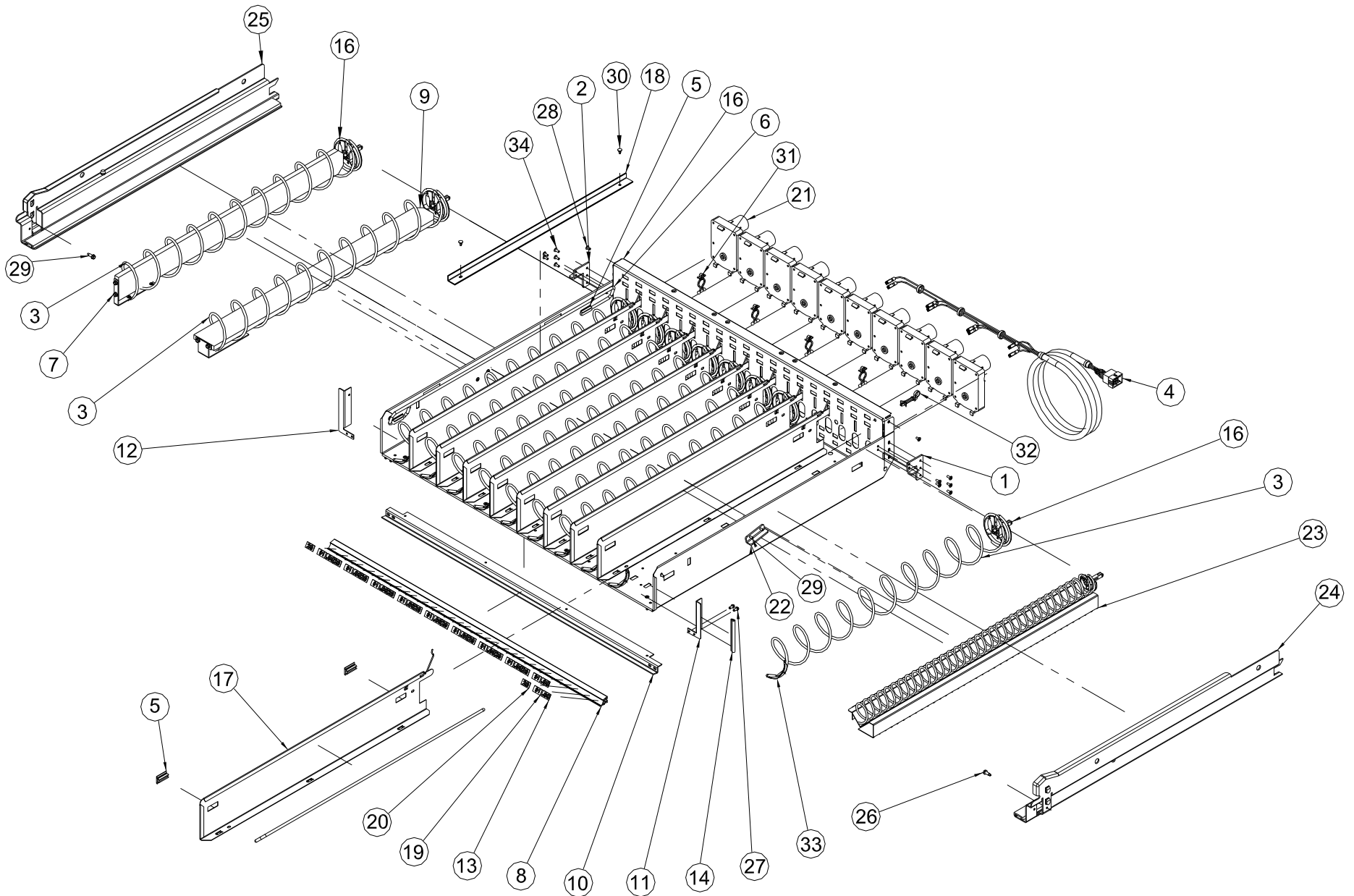

UNIVERSAL (SNACK/CANDY/FOOD) TRAY PARTS LIST

ITEM	PART NO.	PART DESCRIPTION	NOTES
1	20073	Tray Stop	
2	20073-01	Tray Stop, LH	
3	-----	Helix	1 Per Column. See Helix Section
4	20147	Harness, Tray 10 Column	
5	20220	Extrusion, Candy Pusher	Optional, 2 Per 20221 & Divider With Cutouts
6	20221	Bar, Candy Pusher	Optional, 1 Per Divider With Cutouts
7	20450	Kit, Helix Splitter	Optional, 1 Per Selection
8	20465-02	Extrusion, Price Marker, Reduced Height (35")	
	20465-01	Extrusion, Price Marker, Reduced Height (39")	
9	20535	Kit, Cup Rail, Small Helix	Optional, 1 Per Selection
	20536	Kit, Cup Rail, 4" Helix	
10	20643	Tray Doubler, Ver. 2 (35")	
	20544	Tray Doubler, Ver. 2 (39")	
11	20545	Tray Corner, Ver. 2 (RH)	
12	20545-01	Tray Corner, Ver. 2 (LH)	
13	20614	Label Sheet, Reduced Height, Price	
14	20796-01	Edge Trim, Tray Corner	Right Hand Corner Only
15	21045	Tray Body, Reduced Depth (35")	
	20955	Tray Body, Reduced Depth (39")	
16	20966	Helix Adaptor, Without Hub	
17	21138	Assembly, Tray Divider	Includes Divider With 20133 Spring, Select Type, Numbers To Form Columns
	21139	Assembly, Tray Divider, High	
	23664	Assembly, Tray Divider, Extra High	
18	22192	Helix Alignment Device, PVC	
19	22908	Label Sheet, Reduced Height, Price W/\$	
20	22909	Label Sheet, Reduced Height, Location, White	
21	23007	Motor, With Home Circuit, CCW	Optional
	23007-01	Motor, With Home Circuit, CW	
22	23471	Tray Stop, Intermediate, Slim	
23	24046	Kit, Mini-Dispenser	Optional, 1 Per Selection

ITEM	PART NO.	PART DESCRIPTION	NOTES
24	22250	Assembly, Tray Rail, Snack (RH)	
25	22251	Assembly, Tray Rail, Snack (LH)	
26	3001-03	Screw, Sheet Metal, Type B, #8-18	Safety Screws For Rails
27	3009-02	Rivet, Steel, Black 1/8 Dia X 1/8 Grip	
28	3009-04	Rivet, Steel, Black 1/8 Dia X 1/4 Grip	
29	3019	Canoe Clip	2 Per Helix Alignment Device
30	3020	Wire Tie, Stand Off	
31	3042-01	Wire Tie, Panel Mount	
32	3111	Helix Ejector	
33	3295-03	Rivet, Steel, 1/8", Plated	

NOTE: Tray also comes in scrolling price option. Contact your AMS distributor for details.

THIS PAGE INTENTIONALLY LEFT BLANK

35" and 39" HIGH CAPACITY HEAVY PRODUCT TRAY ILLUSTRATION

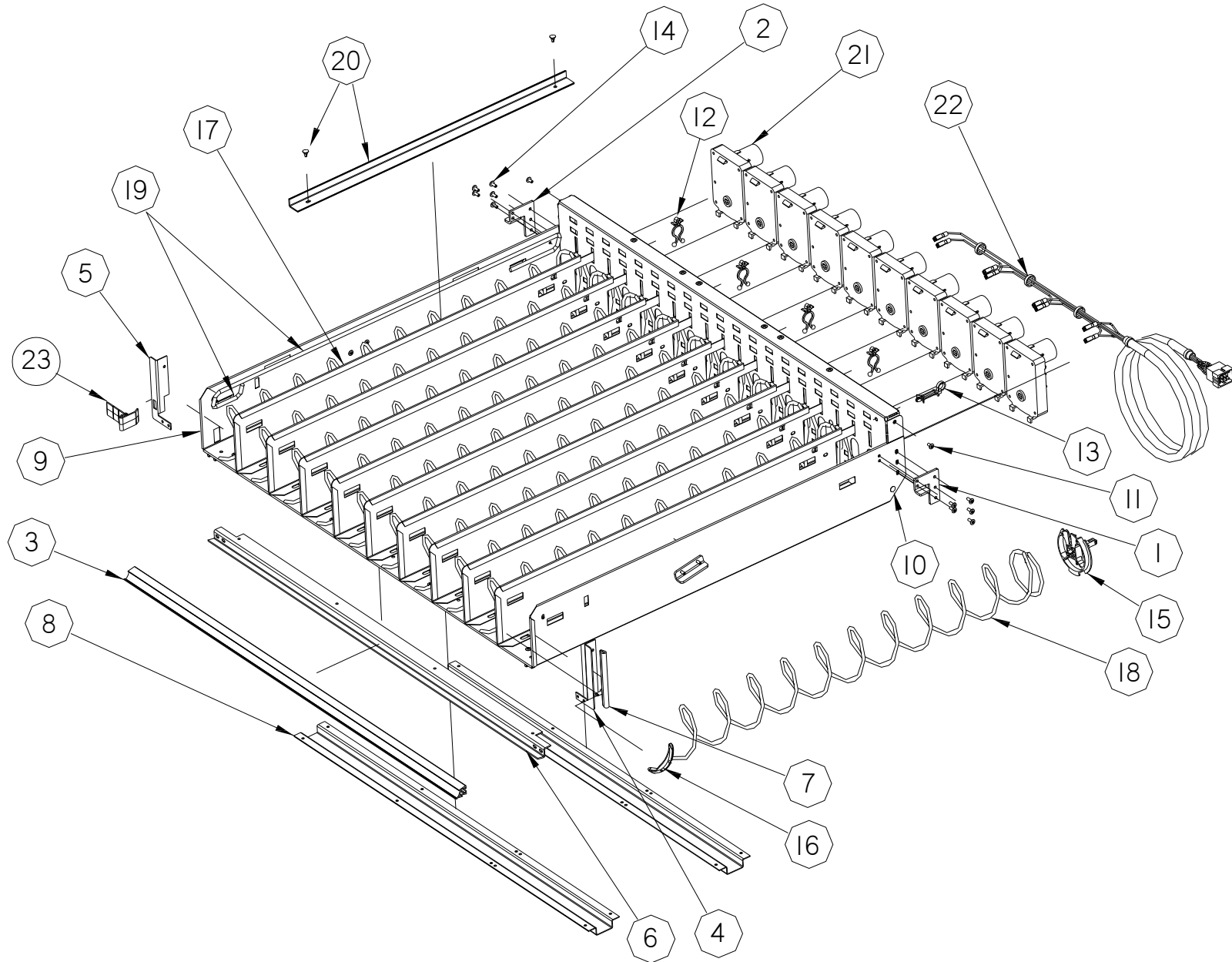

35" and 39" HIGH CAPACITY HEAVY PRODUCT TRAY PARTS LIST

ITEM	PART NO.	PART DESCRIPTION	NOTES
1	20073	Tray Stop	
2	20073-01	Tray Stop, LH	
3*	20465-02	Extrusion, Price Marker, Reduced Height (35")	
	20465-01	Extrusion, Price Marker, Reduced Height (39")	
4	20545	Tray Corner, Ver. 2 (RH)	
5	20545-01	Tray Corner, Ver. 2 (LH)	
6	20643	Tray Doubler, Ver. 2 (35")	
	20544	Tray Doubler, Ver. 2 (39")	
7	20796-01	Edge Trim, Tray Corner	Right Hand Corner Only
8	21958	Tray Reinforcement (35")	
	22831	Tray Reinforcement (39")	
9	24094	Tray Body, HCHP, Reduced Depth (35")	
	24055	Tray Body, HCHP, Reduced Depth (39")	
10	3019	Canoe Clip	
11	3009-02	Rivet, Steel, Black, 1/8 Dia.. X 1/8 Grip	
12	3020	Wire Tie, Standoff	Optional—Contact Your Distributor
13	3042-01	Wire Tie, Panel Mount	
14	3295-03	Rivet, Steel, 1/8", Plated	
15	20966	Helix Adaptor, Without Hub	
16	3111	Helix Ejector	
17	23333	Tray Divider, 3-3/8"	Select Type, Numbers To Form Columns
	23334	Tray Divider, 4-7/8"	
	23335	Tray Divider, 8"	
18	-----	Helix	1 Per Column – See Helix Section
19	20449	Assembly, Candy Pusher	Optional – Contact Your Distributor
20	23622	Assembly, Helix Alignment Device	Optional – Contact Your Distributor
21	23007	Motor, With Home Circuit, CCW	Optional – Contact Your Distributor

ITEM	PART NO.	PART DESCRIPTION	NOTE
22	20147	Harness, Tray, 10 Column	
23	26774	Universal Tray Clip, .75"	
—	3001-03	Screw, Sheet Metal, Type b, #8-18	Supplied, Not Shown
—	22834	Assembly, Heavy Product Rail, Service, RH	Supplied, Not Shown
—	22835	Assembly, Heavy Product Rail, Service, LH	Supplied, Not Shown

*Tray also comes in scrolling price option. Contact your AMS distributor for details.