

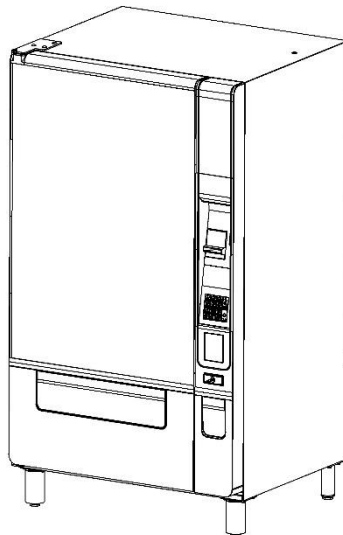

EVOKE

**AMBIENT GENERAL MERCHANDISER
GLASSFRONT VENDOR**

SERVICE MANUAL



MODELS:

3605 – EVOKE 5000 (5 WIDE)

3606 – EVOKE 6000 (6 WIDE)

TABLE OF CONTENTS

SAFETY WARNINGS & SPECIFICATIONS	4
INTRODUCTION	5
EVOKE GENERAL MERCHANDISER.....	5
AMERICANS WITH DISABILITIES ACT (ADA).....	5
SERVICING	5
EVOKE 5000 AT A GLANCE	6
UNPACKING	7
INSTALLATION	7
REMOVING THE SWING DOOR	7
REMOVING THE PULL-OUT DOOR	8
POWER CORD.....	10
POSITIONING & LEVELING VENDOR.....	10
GROUNDING (EARTHING) & ELECTRICAL.....	10
MAIN POWER SWITCH	10
LOADING PRODUCTS.....	11
SPIRAL ADJUSTMENT	12
DOOR SWITCH.....	12
SERVICE MODE.....	12
MOTOR PAIRING	13
INSTALLING A COIN CHANGER.....	13
CASH BOX.....	13
BILL VALIDATOR OPERATION (OPTIONAL)	14
IVEND™ ASSURANCE.....	14
PREVENTIVE MAINTENANCE.....	15
PARTS ORDERING PROCEDURE.....	16
BEFORE CALLING FOR SERVICE	16
EVOKE ELECTRICAL SCHEMATIC.....	17
EVOKE CONTROL BOARD	18
NOTES:.....	20

SAFETY WARNINGS & SPECIFICATIONS

WARNINGS

1. In cases where there is no fuse in the plug of the power cord, the primary over-current electrical protection is provided by the buildings power distribution board.
2. This vendor is not intended for use by young children or the infirm unless aided or supervised by an adult or an abled-bodied person.
3. This vendor must be level for proper operation, door to door alignment, cabinet to door alignment for acceptance of coins through the coin mechanism see Installation section pg. 9
4. This vendor is designed to dispense pre-packaged products for hygiene & safety purposes and no surfaces should ever come into direct contact with the food to be consumed.
5. For the purposes of food handling, replenishing and hygiene maintenance operating personnel should have received the required training and instruction as mandated by the local authority responsible.
6. This vendor is designed for indoor use and must not be installed in a location where a water hose/jet could be used.

DIMENSIONS & WEIGHTS

TYPE	EVOKE 5000	EVOKE 6000
MODEL	3605/3605A	3606/3606A
WIDTH	41" (183cm)	45" (114.3 cm)
DEPTH	35.2" (89.4cm)	35.2" (89.4cm)
HEIGHT	72" (183cm)	72" (183cm)
ESTIMATED WEIGHT ¹	526lb (239kg)	566 (257kg)
EST. SHIPPING WT. ¹	564lb (256kg)	604 (275kg)

Note: ¹ Weights will vary depending on tray configuration and optional equipment installed.

MANUAL REVISION HISTORY

REV	DATE	REASON
A	01/31/2017	Initial release

ELECTRICAL

MODEL	3605/3606	3605A/3606A
VOLTAGE	115 VAC	230 VAC
CYCLE	60 Hz	50/60 Hz
NOMINAL AMPS	1.2 Amps	0.7 Amps
TRANSFORMER	110/24 VAC	230/24 VAC

COIN CHANGER, BILL VALIDATOR, CARD READER

TYPE	MDB Coin Changer level II or III, Bill Validator Level I, Card Reader Level I or II
------	---

VENDOR OPERATION

LOCATION	Suitable for indoor use only. This appliance is not suitable for installation in an area where a water jet could be used.
SOUND LEVEL	PRODUCES LESS THAN 20 DBA DURING NORMAL OPERATION.
RECOMMENDED OPERATING TEMPERATURE	Between 40°F and 90°F (4° and 32° Celsius)
CLIMATIC CLASS	SN (Sub-Normal)

INTRODUCTION

This manual contains instructions, service and installation guidelines for the **Evoke Glassfront Vendor**. Please read this manual thoroughly and follow the instructions. The initial set-up of a vendor is a very important step of insuring that the equipment operates in a trouble-free manner.

EVOKE GENERAL MERCHANDISER

The **Evoke** is an ambient temperature glass fronted vendor. The **Evoke** design gives great emphasis to presenting the equipment and the merchandise in the best possible way, using the latest efficient techniques and materials. The window area and product lighting have been maximized to optimize the shopping experience.

The consumer interface area has been laid out to provide a wide range of flexibility for an endless choice of payment systems to provide the highest accessibility for all locations/environments.

Guaranteed assurance or product delivery is facilitated by iVend, this is an enhanced Infra-Red product detection system that ensures a product has been delivered before accepting payment.

The **Evoke** provides a choice of User Interface, an ergonomic tactile keypad with clear backlit number legends and Braille numbers on each key. The keypad in combination with a color 3.5" graphical display provides a simple and intuitive means to operate the machine.

Alternatively, there is the option of a large 10" Capacitive Touch Screen, the screen and supporting systems provide a range of tools to present full planogramming and nutritional information to the consumer customer, enabling them to make informed and best choices. Running promotions and loyalty schemes all become easy and effective. The 'open architecture' of the **Evoke** systems make it possible for operators/customers to develop, control and run their own bespoke applications.

AMERICANS WITH DISABILITIES ACT (ADA)

The **Evoke** is fully compliant with Americans with Disabilities Act (ADA) that ensures the vendor is accessible to wheelchair customers. The side reach regulations require that all operable parts of the vending machine are to be no higher than 48 inches and no lower than 15 inches from the ground.

The collection of purchased items can also be done single handedly with an operating force of no greater than 5lb (2.25kg), a friendly, quick and visible experience that doesn't involve fumbling.

SERVICING

The internal design and layout of the machine allows for quick & easy service access for both filling and maintenance/service procedures.

All programming (pricing, vend functions and features) is set-up within the **Evoke** control system. Parameter changes can be made without any additional accessories or remote parts. Selections can be priced individually from \$00.00 to \$655.35 in five cent increments (US currency).

Full cash/cashless accountability records, total vend cycles performed by the vendor, information on individual selections, complete rows or total vendor can be viewed, downloaded or sent remotely via telemetry using the DEX utility. Electrical malfunctions are recorded and displayed when the vending vendor is placed in the **Service Mode**. Non-functional/functional motors or selections are identified in a simple map.

The vending sequence is "first-in, first-out" for each selection, controlling stock rotation to maintain fresh products in the vending area.

There are many features and options that can be taken advantage of e.g. Promotions, Time Events, Discounting, Shutdown, Space to Sales, Motor Pairing. For full details refer to the **4225134 Evoke Programming Manual** which can be found and/or downloaded from <http://www.vendnetusa.com/Manuals/Snack> .

EVOKE 5000 AT A GLANCE

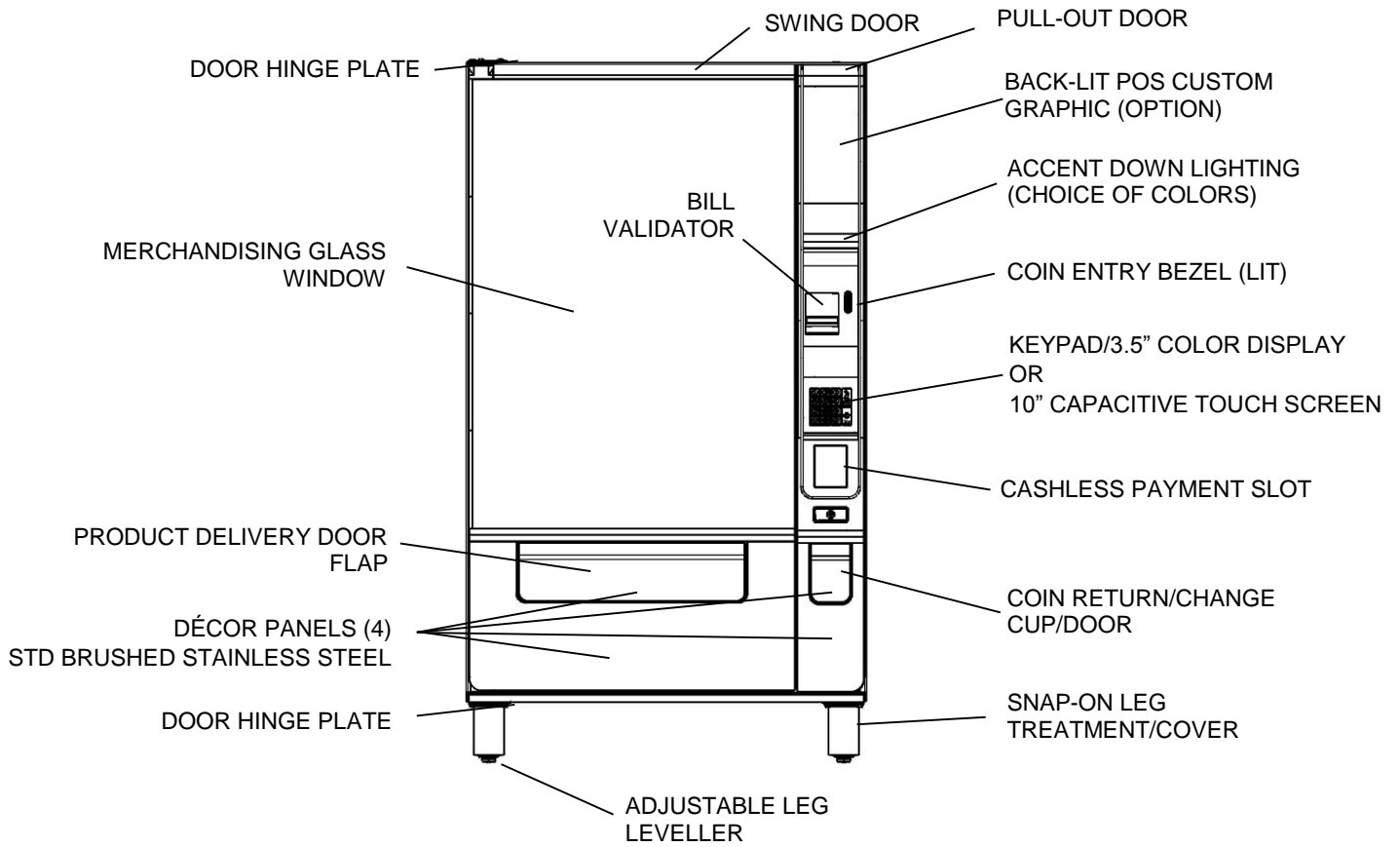

UNPACKING

This Evoke vendor was thoroughly inspected before leaving the factory and the delivering carrier has accepted this vendor as their responsibility. Please note any damage to packaging and/or machine at the time of delivery and report them to the carrier. Request a written inspection report from the claims inspector to file any claim for damage. File the claim with the carrier within 7 days after receipt of the vending vendor.

Carefully remove the outside packing material so as not to damage the finish or exterior of the vending vendor. Inspect the vending vendor for concealed shipping damage. Immediately report any damage hidden by the shipping material directly to the delivering carrier on a hidden damage report.

Record the model number and serial number of the vendor for your records. These numbers can be found on the serial plates on the rear of the cabinet and/or inside the vendor. Refer to these numbers in all correspondence and inquiries pertaining to this vendor.

To remove the 2-wooden skid boards use a chisel or small crow bar to split the partly cut boards at the front/Rear, see Fig 1a. Then turn the leveling screws in as far as possible prior to final placement.

The leg covers can be found in the delivery bin. Install these once the vendor has been placed on location and leveled, see Fig 1b).

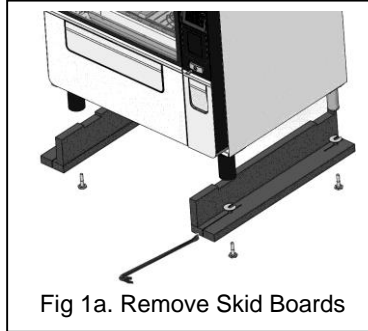

Fig 1a. Remove Skid Boards

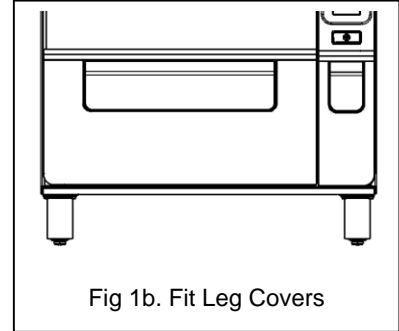

Fig 1b. Fit Leg Covers

INSTALLATION

- Consult local, state and federal codes and regulations before installing the vendor.
- Retrieve the keys to the vendor from the coin return cup.
- Open the 'pull-out door' and then the 'swing door' and remove all internal packing material.

WARNING: Position and level the vendor prior to connecting vendor to power. All set up steps must be completed prior to prevent harm to the installer or vendor and to ensure correct operation.

REMOVING THE SWING DOOR

The vendor will fit through most doorways (34"+) by opening the 'swing door' and carefully walking the vendor door or cabinet through first and then moving the remaining portion of the vendor through.

The vendor 'swing door' may be removed to permit easier movement through a narrower door openings or hallways. To remove the 'swing door':

1. **Disconnect Cabinet to Door harness:**
 - Cut the nylon tie strain relieving the harness to side of delivery bin
 - Unplug the connector as shown in Fig 2.

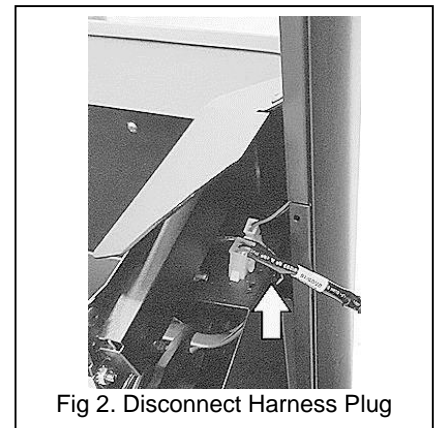

Fig 2. Disconnect Harness Plug

2. **Remove the 'Swing Door':**

CAUTION: This requires two people.

First mark an outline around the top hinge plate with a pencil to be sure the hinge is set back into the same position. Open the door at least 90 degrees and remove the (3) Carriage Bolts by undoing the nuts with a deep 1/2" socket, these fasten the top hinge plate to the cabinet top as shown in Fig 3.

Once the bolts are removed the door needs to be lifted vertically off the bottom hinge, see Fig 4.

NOTE: The bottom hinge pin rests on top of (2) nylon washers to provide proper door height and smooth operation; these washers **must** be retained for reassembly.

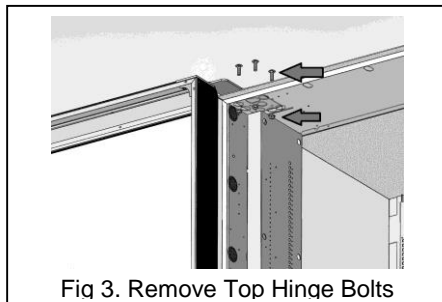

Fig 3. Remove Top Hinge Bolts

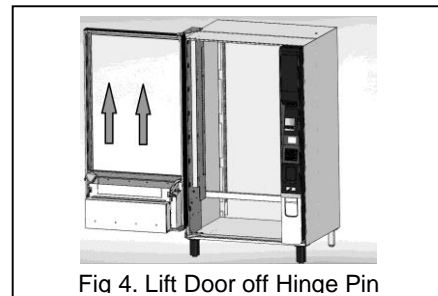

Fig 4. Lift Door off Hinge Pin

REMOVING THE PULL-OUT DOOR

If it proves necessary to reduce the machine depth to approximately 31" the pull-out door can be removed as follows:

1. Remove the (2) stop screws from the top and bottom slider channel as shown in Fig 5. Top Hinge:
2. The Pull-Out Door can now be brought out further to provide better access.
NOTE: Ensure the 2 screws are replaced at the end of the procedure to prevent the slides being damaged

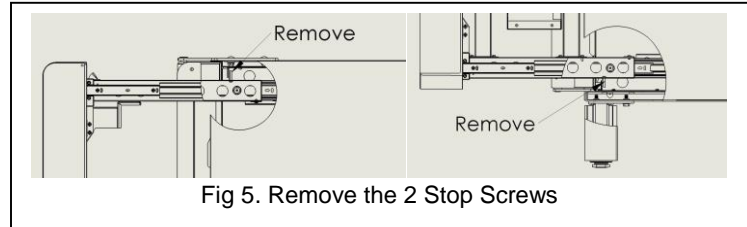

Fig 5. Remove the 2 Stop Screws

3. Remove/disconnect the (8) 'P' Clamp and harness connections as shown in Fig 6.
Feed all the cables down through the square hole in the base panel to enable the front assembly to be removed.

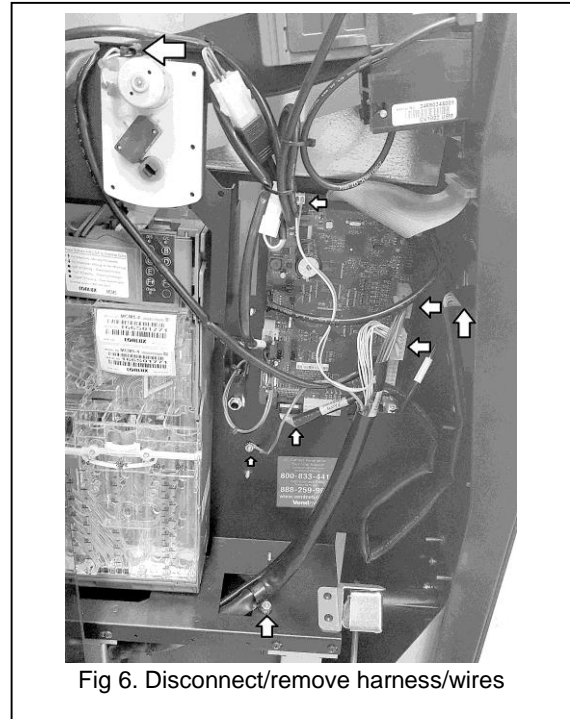

Fig 6. Disconnect/remove harness/wires

4. Remove and retain the (4) screws that connect the Coin mechanism panel to the 2 upright Tie Bars.
Remove and retain the (2) screws that connect the support gusset to the front Tie Bar as shown in Fig 7.

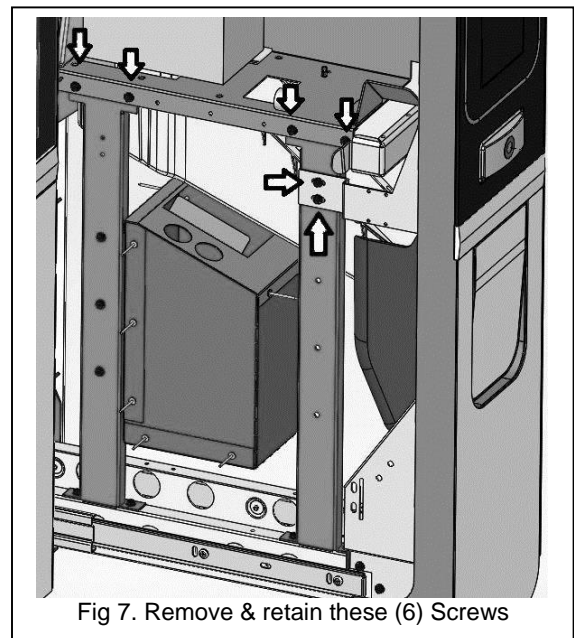
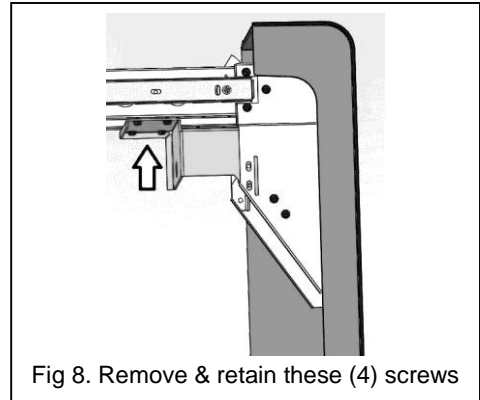

Fig 7. Remove & retain these (6) Screws

REMOVING THE PULL-OUT DOOR . . . Contd.

- Remove the (4) screws from the top brace as shown in Fig 8



- Starting at the bottom, remove and retain the (3) screws from each of the (4) top & bottom slide rail both sides of the pull-out door, see Fig 9.

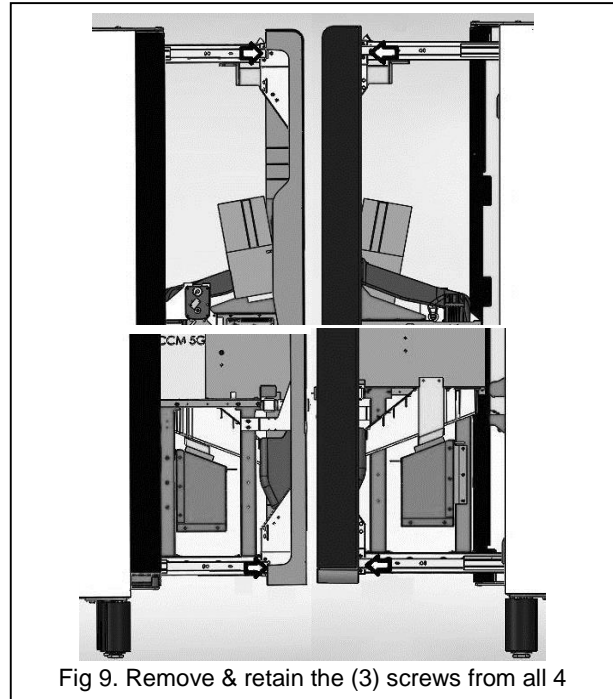

- The Pull-Out Door can now be dismantled from the (4) slide rails and pulled free as shown in Fig 10. Carefully move to a free area and rest firmly against a solid upright out of 'harm's way'.

Push the slide rails back in until they lock and continue to maneuver the machine through the restriction.

Reverse the above procedure/s to reassemble.

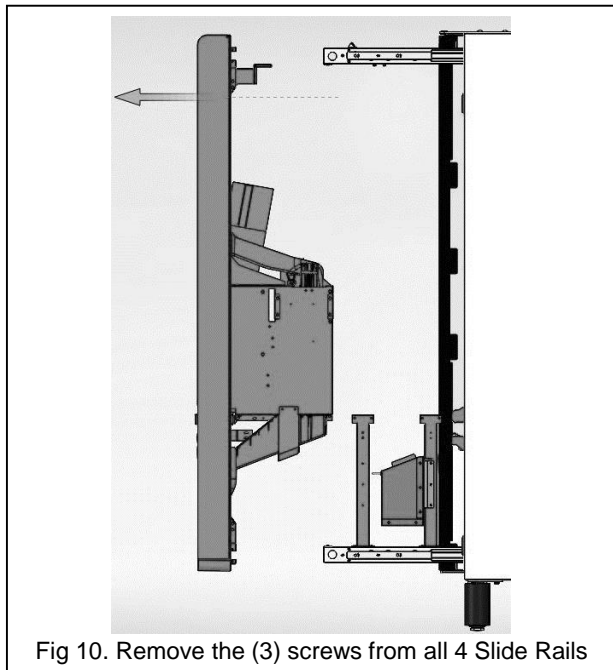

POWER CORD

Loosen the (4) screws fixing the connection box cover, remove the cover and park on (2) screws as shown in Fig 11. The power cord and GFCI can be removed from its housing, the cover can then be replaced and secured. Keep the power cord secured on the center back of the cabinet until the vendor is placed into its final location to avoid damage to the cord.

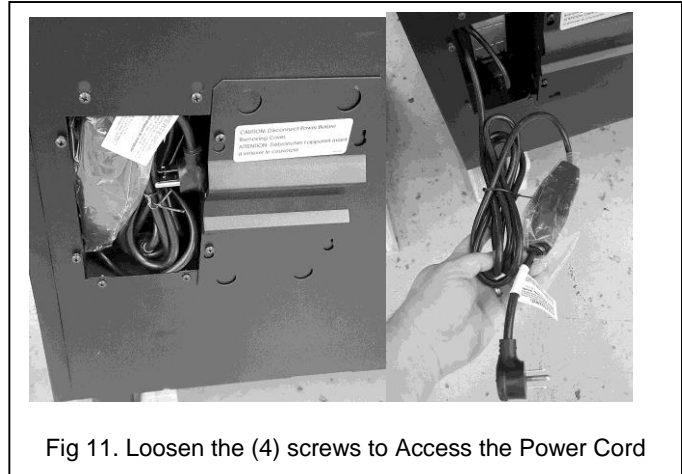

POSITIONING & LEVELING VENDOR

Position the vendor in its place of operation within 6 ft (183cm) from the power outlet or receptacle. Check that the 'swing door' has clearance on the left side to allow sufficiently to service/load the trays, see Fig 12. Leave at least 4" (10cm) inches between the back of vendor for air circulation.

All levelers must touch the floor. **The vendor must be level for proper operation for thee coins and to correctly align the 'swing' and pull-out doors.**

Adjust the four (4) leg levelers on the cabinet legs to make the cabinet level front-to-back and left-to-right, use a spirit level or similar to verify.

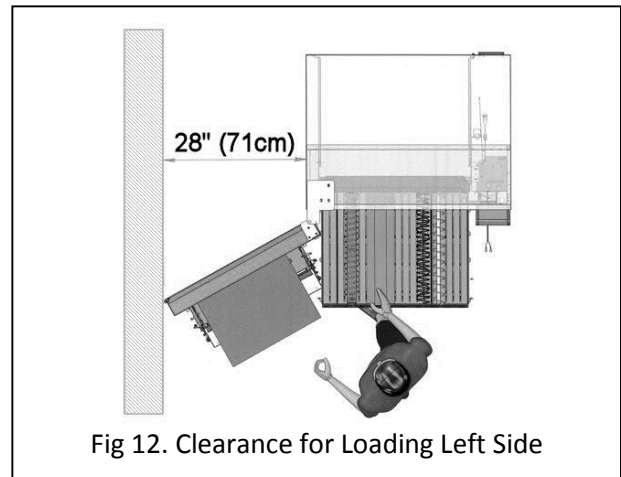

IMPORTANT

GROUNDING (EARTHING) & ELECTRICAL

Consult local, state, and federal codes and regulations before installing the vendor.

Before connecting the vendor, the integrity of the main electrical supply must be checked for correct polarity, presence of ground (earth) and the correct voltage. These checks should be repeated at six-month intervals with the routine safety electrical testing of the vendor itself.

If the receptacle is not properly grounded or polarized, contact a licensed electrician to correctly polarize and/or ground the receptacle to ensure safe operation.

For proper operation of any equipment utilizing electronically controlled components, the equipment should be placed on a dedicated, noise-free circuit and be properly polarized and grounded. Use of a surge conditioner/suppressor is recommended for locations where electrical noise is present.

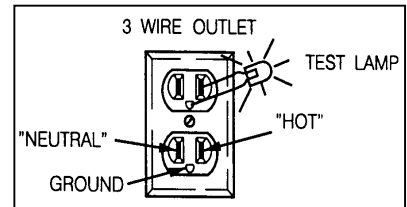

MAIN POWER SWITCH

Plug the power cord into the power outlet.

Open the vendor 'Pull-Out' door and turn ON the main power switch located on the face of the power panel within inside the cabinet, see Fig 13.

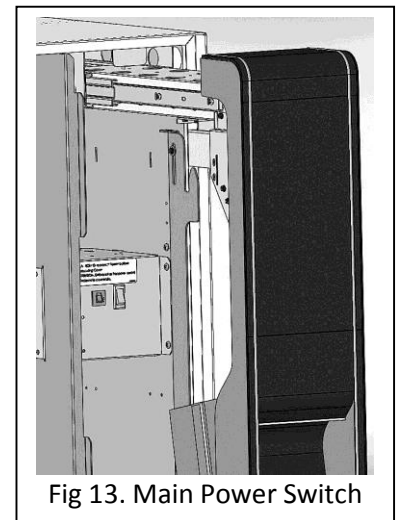

LOADING PRODUCTS

Load products from front to back making sure all items fit freely between the spiral spaces. Do not attempt to force oversize items or packages into the spiral spaces. Do not skip a space. Place the product on the bottom of the compartment on the product spirals on the tray floor and do not bridge across the spiral. The product label is to be facing the front of the vending vendor for easy identification by the customer, see Fig 13.

IMPORTANT: Some product packaging can cause the item to hang on the tray edge, in these cases it is recommended to install product pushers to assist with the ejection/release – part number 4226049 Product Pusher

GENERAL LOADING

To load products, lift the tray slightly at front and pull forward until the tray stops. The trays will tilt once pulled forward for easier loading.

The standing height of the item being vended must be taller than the diameter of the spiral being used to vend correctly, see Fig 14.

By re-timing the spirals, difficult-to-vend items can most times be dispensed more dependably. If the product does not fit the spiral properly i.e. if there is any interference, use a different pitched spiral to provide more space. Call the number at the back of this manual for spirals available from your distributor or service entity.

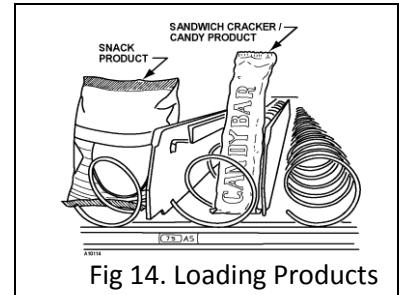

Fig 14. Loading Products

TRAY ADJUSTMENTS VERTICAL SPACING

By altering the space between trays larger items can be vended. The trays can be adjusted up or down in half-inch increments to provide headroom for the products. When increasing the height in one area, the same amount of room will be lost in the tray above or below the one being adjusted. See Fig 15.

CANDY, SNACK AND 3/4 SNACK TRAY ADJUSTMENTS

All trays have adjustable divider locations. By adding, removing, or relocating divider positions a wide variety of selection compartment widths can be derived as required, see Fig 16. The dividers can be located in every 1/2 Candy position. This adjustment provides for **CANDY** (candy bars, crackers), **3/4 SNACK** (small chip bags, cookies), and full sized **SNACK** (chips, pastries) compartment sizes. Adjustments can also be made for compartments wider than a SNACK compartment width for larger/wider items. Every tray provides motor connections for the maximum number of selections per tray. Additional parts (dividers, motors, spirals, and adapter kits) are available.

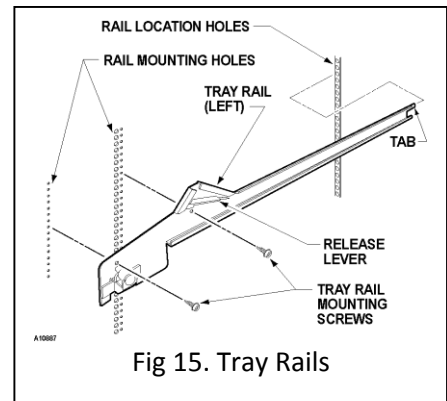

Fig 15. Tray Rails

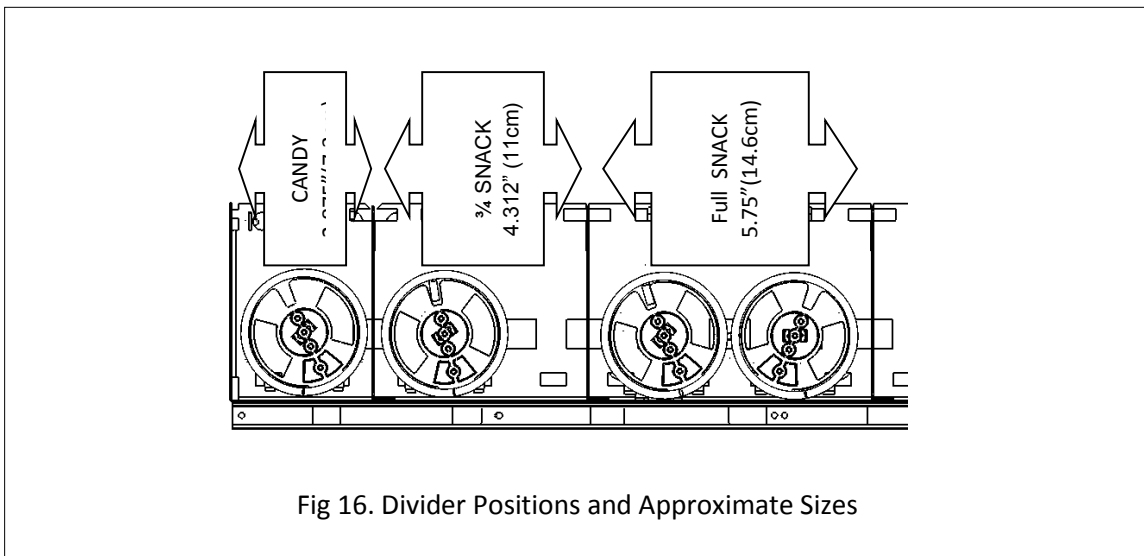
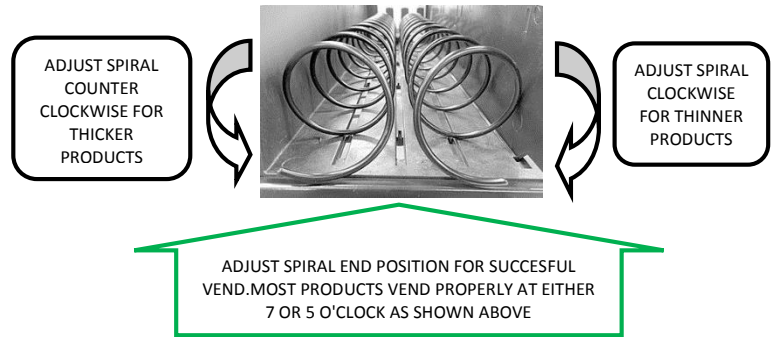

Fig 16. Divider Positions and Approximate Sizes

SPIRAL ADJUSTMENT

The shape, size and thickness of a product affect how well it is ejected from the tray. Most products can be vended successfully when the spiral end is positioned at 7 or 5 o'clock. If vending problems occur with spiral ends at the standard positions, adjust the drop-off either by retiming the spiral or installing a Product Pusher.



DOOR SWITCH

The door switch is located on top of the Pull-Out Door slide housing, see Fig 17. The door switch is monitored by the Evoke control system, when the pull-Out Door is opened the display will show and errors that may have been logged. To reset the errors displayed press the # key.

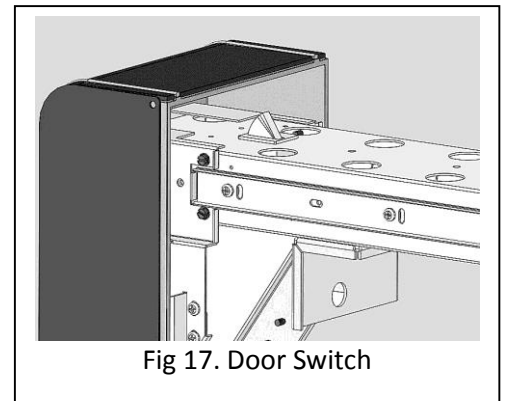

SERVICE MODE

Use the **Service Mode** to program and service the vendor. Use the keypad as an input device. Observe the display for information while in Service Mode.

SERVICE MODE BUTTON

To enter **Service Mode**, press the **Service Mode Button** once, it is located in the bottom left hand corner of the control board, see Fig 18. To exit Service Mode, press the Service Mode Button again once or press the * key 3 times.

NOTE: If no key is pressed for approximately one minute while in Service Mode, the controller will automatically return to Sales Mode.

For all programming features and functions please refer to the **4225134 Evoke Programming Manual** which can be found and/or downloaded from <http://www.vendnetusa.com/Manuals/Snack> .

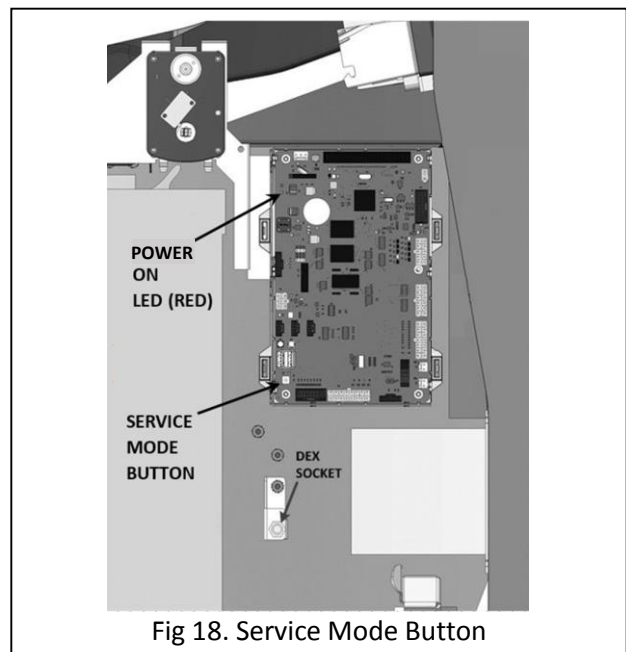

MOTOR PAIRING

The 'motor pairing' feature facilitates the ganging together of 2 individual motors, so that when a single selection code is entered both motors will operate together; the LH motor will rotate CCW and the RH motor will rotate CW, the corresponding spirals also have to be CCW & CW.

This feature allows the 2 motors to be spread apart from each other to suit the width of the item to be vended. The selection width can be as little as 5 3/4" (14.6cm) or the paired motors/spirals can span the entire width of the shelf e.g. ganging selection motors 40 & 49.

The 2 'paired motors' have to be wired to suit the physical span between them, this will determine the selection numbers to be paired.

See the 4225134 Programming Manual for instructions to set-up 'paired motors'.

INSTALLING A COIN CHANGER

1. Mount the changer unit onto the 3 screws provided and then secure, See Fig 19.
2. Check the alignment between the underside of coin entry chute and top of entry hopper, adjust chute so there is only 1/8" (3mm) clearance.
3. With the machine switched ON press the coin return button to check the operation of the coin return. Ensure that the reject lever on the coin mechanism is actuated sufficiently by the motor cam to clear bent coins, adjust by slackening the screws securing the coin return motor bracket and adjusting up/down; retighten the screws when complete.
4. The Coin Changer must be loaded with some coins in each tube for the vendor to operate properly and allow the bill validator to accept most bill denominations, a minimum of 50% is recommended.
5. To fill the coin tube first press the Service Mode button on the control board, then there will be no restriction on the amount of coins that can be accepted. When exiting service mode any credit is cleared to zero.

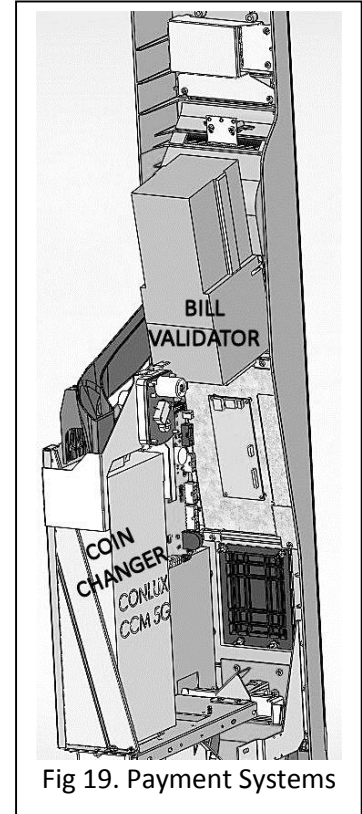

Fig 19. Payment Systems

CASH BOX

To remove the cash box lift it vertically upwards to release the shouldered bushes from the keyhole mounting slots at the back of the box, then pull forward to release, see Fig 20. When returning the cash box align the shouldered bushes with the keyholes in the rear mounting plate pushed and allow the cash box to sit down.

IMPORTANT:

1. Ensure that the cash box is in position before closing the pull-out door

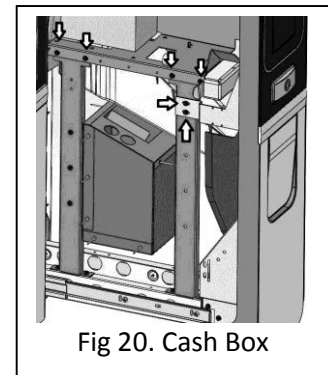
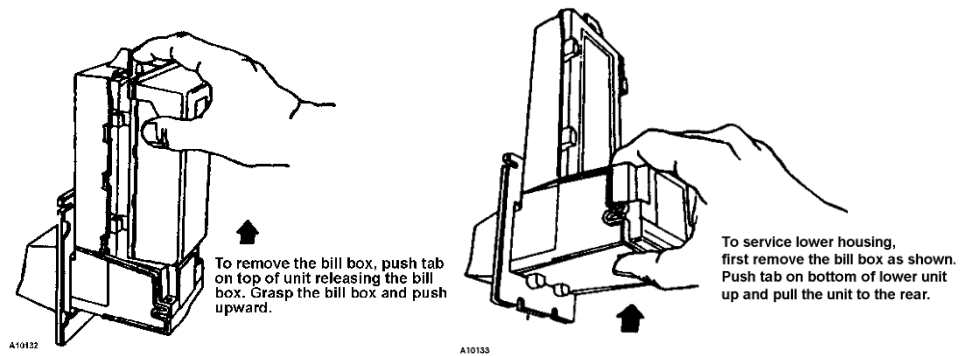

Fig 20. Cash Box

BILL VALIDATOR OPERATION (OPTIONAL)

To remove the bills from the Bill Validator push the tab on the top of the bill box and lift up. To clear jams or cleaning unlatch lower unit as shown. Dollar Bill Validator cleaning instructions as well as more advanced service information can be obtained on the Service portion of the website listed at the end of this manual.



IVEND™ ASSURANCE

All selections have been assigned at the factory to be monitored for iVend™ optical sensing. At the start of a vend, the iVend™ optical sensor will be checked to make sure it is not blocked, damaged or disconnected.

If iVend is blocked, damaged or disconnected the system can be configured to react in one of 2 programmable ways i) to operate with a single turn of the vend motor and credit will be taken regardless or ii) the machine will be rendered out of service.

When iVend is operating normally the vend motor and a vend timeout timer are started, the selection motor/s rotate/s a full turn (360°) to the home-switch position, if a product is detected dropping into the delivery bin the vend is considered successful.

However, if the home-switch position is reached and a product has not been detected, then the vend motor will pause for 1 second while the controller continues to monitor the optical sensor for product delivery and then if a product is detected during this pause the vend is considered successful. If a product is not detected, then the controller initiates a second motor cycle while continuing to monitor the optical sensor.

If a product is detected during this second cycle, the motor will be stopped immediately. The vend is considered successful. The **2ND VEND** accounting counter is increased by one.

If after reaching the home-switch position and a product has not been detected, then the vend motor is stopped and for 2 seconds the controller continues to monitor the optical sensor for product delivery. If a product is detected, the vend is considered successful. The **2ND VEND** accounting counter is increased by one.

If no product is detected, the selection is logged as 'sold out'. Such a state will trigger to display the **MAKE ANOTHER SELECTION** message. The original credit remains and is displayed, the customer can press selection buttons to activate this or another motor or press the coin return button.

DISPLAY CREDIT - ELECTRONIC PRICING

This vendor is equipped with Electronic Pricing, the customer may verify the price by pressing the selection number before inserting money. If a selection is made and credit has not been established, the price for that selection is displayed and the customer is prompted "INSERT MONEY". When money or credit is accepted, then the amount of credit is displayed/confirmed.

"USE EXACT CHANGE ONLY" MESSAGE OPERATION

If the coin levels in the coin mechanism tubes are below the low-level sensors, "USE EXACT CHANGE ONLY" will be displayed. This indicates the Coin Changer does not have enough coins in the coin change tubes to make/return change. This also indicates that the Dollar Bill Validator may be disabled until change can be made.

PREVENTIVE MAINTENANCE

CAUTION: Always disconnect power source BEFORE cleaning or servicing.

IMPORTANT:

To ensure the EVOKE vendor delivers its maximum appeal and earning potential it should be kept clean and hygienic at all times!

WEEKLY

CLEAN CABINET EXTERIOR

Clean with a mild detergent and water, rinse and dry thoroughly.

Plastic exterior parts may be cleaned with a quality plastic cleaner.

DO NOT USE CHEMICALS e.g. chlorine, ammonia as these will attack the plastic and lead to cracking and discoloration.

CLEAN CABINET INTERIOR

Wash with a mild detergent and water, rinse and dry thoroughly. Odors may be eliminated by including baking soda or ammonia in the cleaning solution. Plastic parts may be cleaned with a quality plastic cleaner.

Follow the coin mechanism, bill validator and cashless systems manufacturers recommendation for servicing and cleaning.

The vend mechanisms must be kept clean, any build-up can cause the mechanisms to malfunction.

DO NOT GET THE CLEANING SOLUTION ON ELECTRICAL COMPONENTS.

To insure proper vending keep delivery box area free of dirt and sticky substances.

PARTS ORDERING PROCEDURE

When ordering parts, include the following:

1. The model and serial numbers of the vending vendor for which the parts are needed.
2. Shipping address.
3. Address where the invoice should be sent.
4. The number of parts required.
5. Always refer to the pertinent parts and/or part manual for the correct part number and description of a specific part.

NOTE: When RIGHT or LEFT is used with the name of a part, it means the person is facing the vending vendor with the door closed

6. Any special shipping instructions.
7. Carrier desired: air or air special, truck, parcel post or rail.
8. Signature and date.
9. Purchase order number, if used.

To place your order Call Toll-Free 888-836-3638

OR

Mail your order to:

VendNet™
165 North 10th Street
Waukee, IA 50263 USA

OR

Order your parts online: <http://www.vendnetusa.com/catalog/>

All orders are carefully packed and inspected prior to shipment. Damage incurred during shipment should be reported at once and a claim filed with the terminating carrier.

If you do not have the right parts manual: contact VendNet™.

If you have any questions, check out our Website www.vendnetusa.com or call VendNet™. Ask for the Parts Department. We will be happy to assist you. Email: vendnet@vendnetusa.com

BEFORE CALLING FOR SERVICE

Please check the following:

WARNING: Extension cords can and do cause problems; check the reset button on the GFCI unit

- **DO NOT USE EXTENSION CORDS!**
- If the power is turned on at the fuse box, is the vending vendor the only thing that doesn't work?
- Is the vending vendor plugged directly into the outlet?
- Is the circuit breaker at the fuse box reset?

EVOKE ELECTRICAL SCHEMATIC

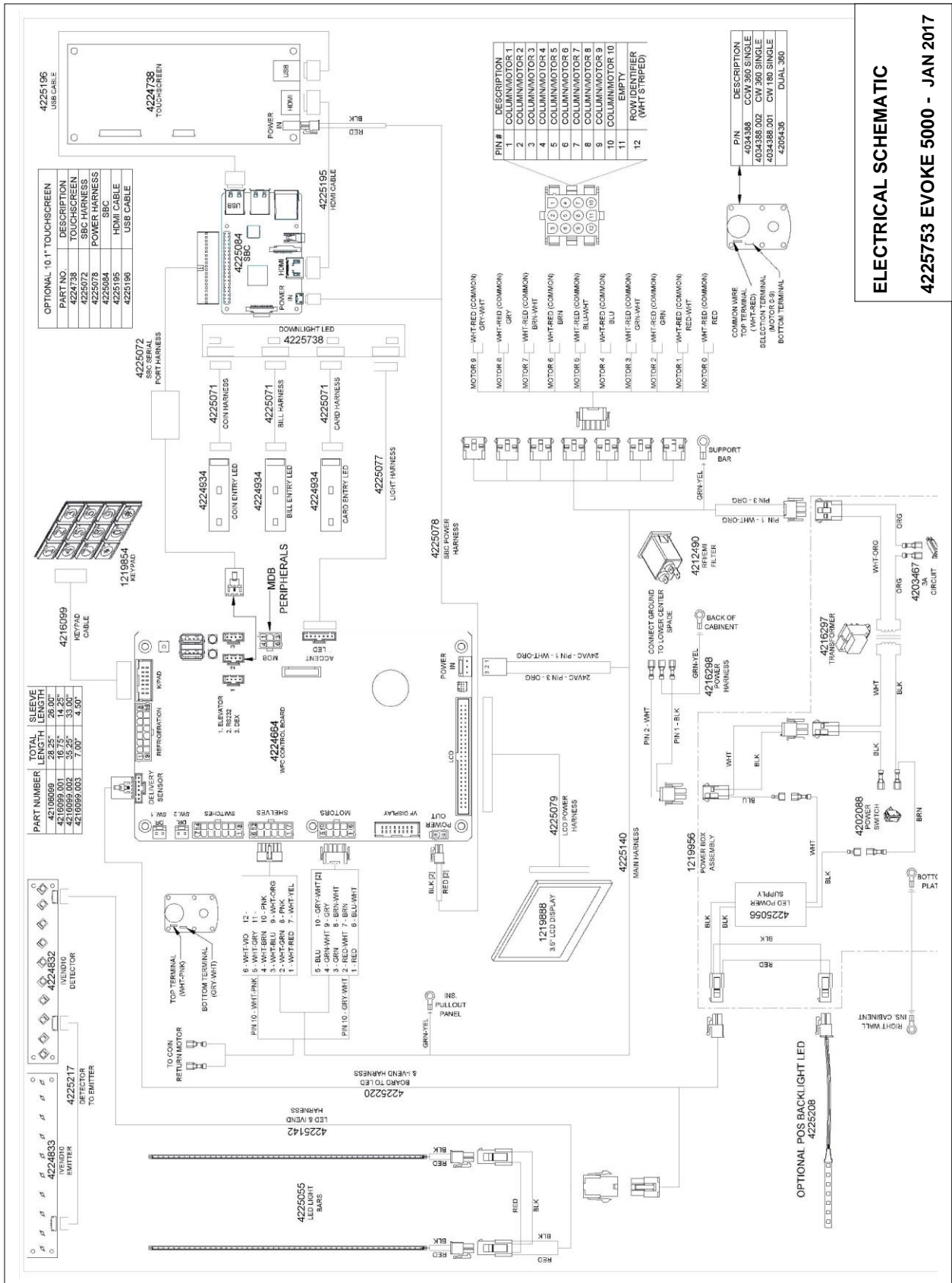

PART NUMBER	TOTAL LENGTH	SLAVE LENGTH
4216099	28.25"	26.00"
4216099.001	16.75"	14.25"
4216099.002	35.25"	33.00"
4216099.003	7.00"	4.50"

PART NO.	DESCRIPTION
4224738	TOUCHSCREEN
4225072	SBC HARNESS
4225078	POWER HARNESS
4225084	SBC
4225195	HDMI CABLE
4225196	USB CABLE

PIN #	DESCRIPTION
1	COLUMN/MOTOR 1
2	COLUMN/MOTOR 2
3	COLUMN/MOTOR 3
4	COLUMN/MOTOR 4
5	COLUMN/MOTOR 5
6	COLUMN/MOTOR 6
7	COLUMN/MOTOR 7
8	COLUMN/MOTOR 8
9	COLUMN/MOTOR 9
10	COLUMN/MOTOR 10
11	EMPTY
12	ROW IDENTIFIER (WHT STRIPED)

PIN	DESCRIPTION
4034388	COM WIRE
4034388.002	TOP TERMINAL (WHT-RED)
4034388.003	SELECTION TERMINAL (MOTOR 9)
4203430	COMMON WIRE
4203430.001	TOP TERMINAL (WHT-RED)
4203430.002	SELECTION TERMINAL (MOTOR 9)
4203430.003	COMMON WIRE
4203430	DUAL 3.00

ELECTRICAL SCHEMATIC

4225753 EVOKE 5000 - JAN 2017

EVOKE CONTROL BOARD

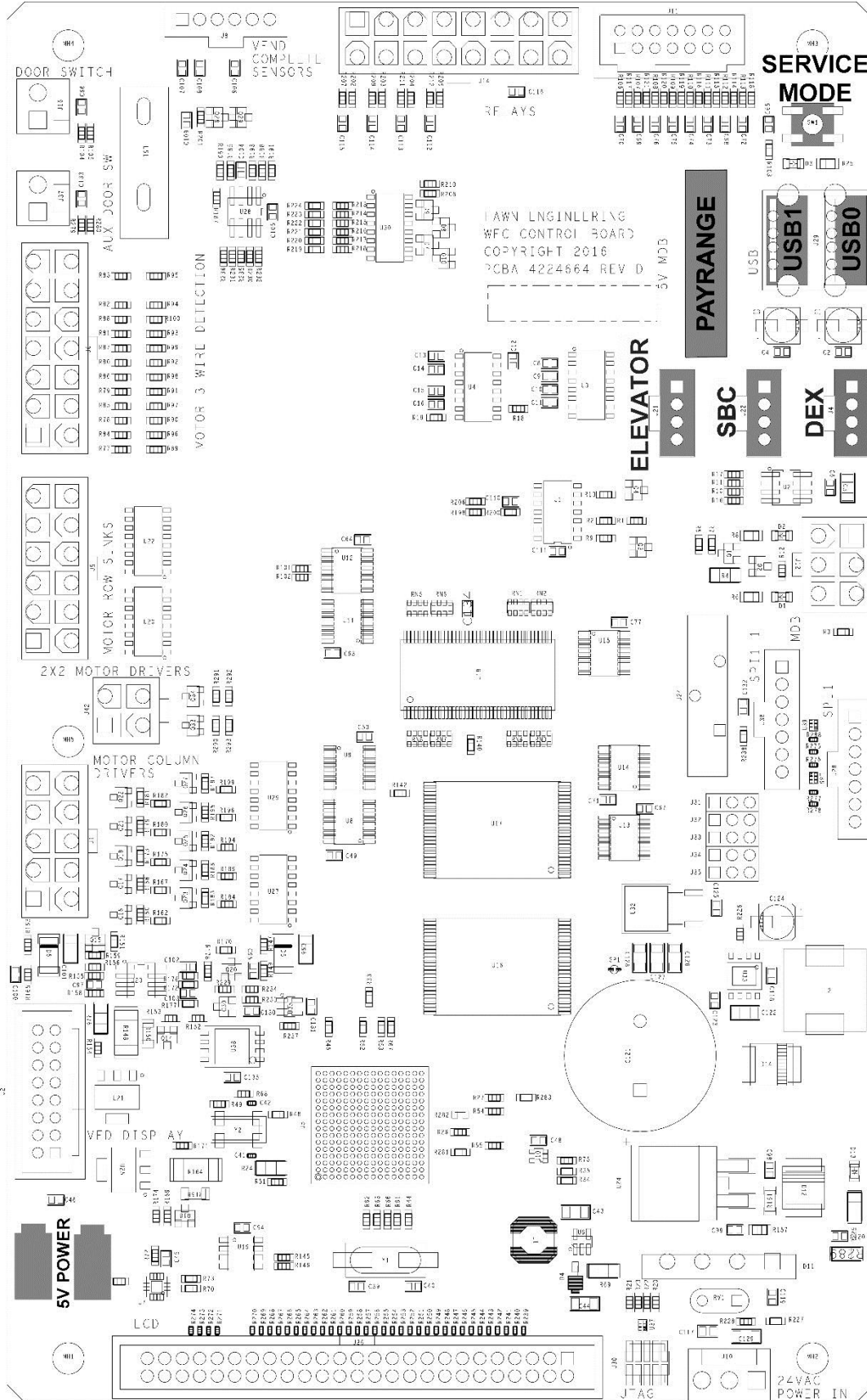

NOTES:

The contents of this publication are presented for informational purposes only, and while every effort has been made to ensure their accuracy, they are not to be construed as warranties or guarantees, express or implied, regarding the products or services described herein or their use or applicability. We reserve the right to modify or improve the designs or specifications of such products at any time without notice.



VendNet™
 165 North 10th Street
 Waukee, Iowa 50263
 United States of America



	USA & Canada	International
Service	(800) 833-4411	(515) 274-3641
Parts	(888) 259-9965	
Email	vendnet@vendnetusa.com	
Web Site	www.vendnetusa.com	

4214792-C.DOC